



THERMAL CYCLER TC-PRO



Instruction Manual

Note: The Boeckel + Co (GmbH + Co) KG reserves the right to modify this manual at any time without notice.

Patent materials are included in this manual. All rights reserved. Any part of this manual shall be forbidden to photocopy, reproduce, or translate into other languages, without written permission from the Boeckel + Co (GmbH + Co) KG

Please read this manual carefully before the Thermal Cycler is first operated!

*Document Number: **BYQ60580100000RSM***
Document Version: Mar, 2008, Version 1.0

Important Note

1 CONVENTIONS

Note: Because there is important information in this item, please read it carefully. Failure to follow the advice here will possibly result in damage or malfunctioning of the Thermal Cycler.

Warning! This symbol means that you should be cautious to take an operation/procedure. Failure to follow the requirements in this item will possibly result in personal injury.

During the operation, maintenance, or repair of the BOECO TC-PRO Thermal Cycler, the following safety measures should be taken. Otherwise, the guard provided by the Thermal Cycler is likely to be damaged, while the rated safety level to be reduced, and the rated operation conditions to be affected.

The Boeckel + Co (GmbH + Co) KG shall not be in any way responsible for the consequences resulted from operators not following the requirements

Note: *The Thermal Cycler, complying with the National Standard GB4793.1, is a general instrument of class II, the protection degree is IP20. It is intended for indoor use.*

a) Grounding Considerations

A.C. power's grounding should be grounded reliably for fear of an electric shock. The 3-pin plug with the Thermal Cycler's power line is a safety device that should be matched with a grounded socket. Never let the third ground pin floating. If the 3-pin plug cannot be inserted, it is recommended to ask an electrician to install an appropriate power socket.

b) Keep Away from Electric Circuits

The operator is not allowed to open the Thermal Cycler. To changing components or adjust certain parameters inside the device must only be accomplished by the certificated professional maintenance personnel. Do not change elements while the power is still on.

c) A.C. Power Considerations

Before turn on the power, always check if the mains voltage is within the required A.C. ($\pm 10\%$ difference is allowed.) and whether the current rating of the power socket meet the required specification.

d) A.C. Power Line Considerations

As an accessory of the Thermal Cycler, the A.C. power line used should be a default one. If

it is damaged, the A.C. power line may not be repaired, but could be replaced by a new one with same model and specification. The power line should be free of heavy objects during the Thermal Cycler's operation. Keep the power line away from the place where people gather regularly.

e) Connect the A.C. Power Line

While connect or disconnect the power line, you should hold the 3-pin plug with your hand. Insert the plug thoroughly to ensure good contact between the plug and socket. Pull the plug, but not the line, when you need to disconnect to the mains.

f) Requested Environments

The Thermal Cycler should be placed in a low-humidity, dust-free, and good-ventilation room without caustic gas or powerful magnetic interference. In addition, water sources, such as pools and water pipes, should be kept a distance from the Thermal Cycler.

Never cover or obstruct the openings of the Thermal Cycler, which are designed for ventilation and prevent the device's interior from being too hot. When a single device is running, the shortest distance between its openings and the nearest object is 50cm; when two or more devices are running at the same time, the shortest distance is 100 cm. Do not place the device on a soft surface, for that will result in adverse ventilation near the device's bottom openings.

Too high temperature will lead to degraded performance or failure of the Thermal Cycler. Therefore, the device should be protected against any kind of heat sources like sunlight, ovens, or central heating equipment.

If the Thermal Cycler is set aside for a long time, it is recommended to disconnect the power line to mains and cover the device with a piece of soft cloth or plastic to prevent dust from entering.

Note:

Once one of the following events occurs, you are suggested to disconnect the power line with mains, and contact the distributor or ask a certificated maintenance personnel for help.

- Liquid into the device;
 - The device sprinkled or drenched;
 - The device malfunctioning, giving off abnormal sound or odor;
 - The device falling onto the floor or its shell damaged;
 - Significant changes in the device's performance.
-

3 LABEL

a) Tablet

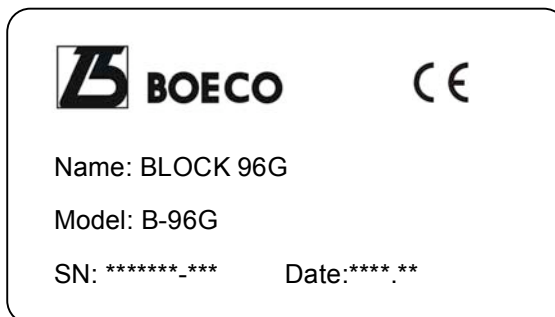
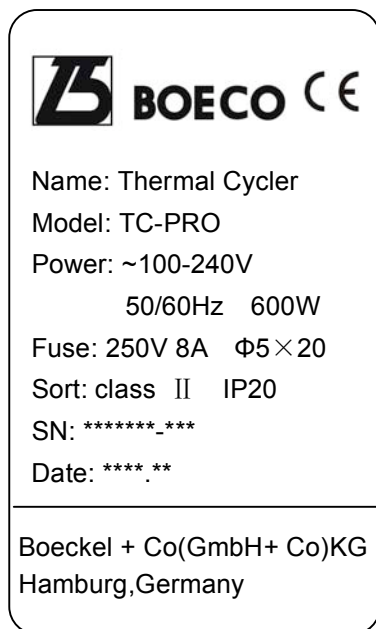

b) Warning Sign



Warning! There are two warning signs read 'HOT SURFACE!' During the program execution and in the short period after the program execution, the metal part near those signs (on the block and hot lid) is not allowed to be touched by any part of the body for fear of the body burn!

4 MAINTENANCE

The conical holes over the block should be cleaned regularly with soaked cotton swab in order to ensure sufficient contact and thus good heat conduction between each conical hole and the tube inside it.

Warning! When cleaning, the instrument should be off.
Corrosive scour is not allowed to clean the surface of the instrument.

5 WARRANTY AND SERVICE INFORMATION

Please refer to the Warranty Card for the detailed information.

Note: Once it is opened, the package should be checked according to the packing list. If the buyer finds any items to be missing or damaged, do not hesitate to contact the distributor.
After the acceptance check is passed, the buyer should fill out the check form and send its photocopy (or fax it) to the distributor. The Boeckel + Co (GmbH + Co) KG establishes the archives and maintenance records with the returned form.
Please store the package and packing materials in a safe place in case of future device maintenance. The above warranty does not extend to goods damaged as the result of cheesy package.

Contents

Chapter One Introduction.....	1
1. Brief Introduction of PCR Technique	1
2. PCR Applications	1
3. Features of BOECO TC-PRO	2
4. Operations of BOECO TC-PRO	3
Chapter Two Specifications	5
1. Normal Working Conditions	5
2. Conditions for Transportation and Storage.....	5
3. Basic Parameters.....	5
4. Performances.....	6
5. Software Functions	6
Chapter Three Preparations	8
1. Structure Description	8
2. Keyboard Diagram	9
3. Keyboard Instructions	9
4. Installation of Block Unit.....	10
4.1 Installation steps	10
4.2 Dismantlement Steps	11
5. Inspections before Power-on	12
6. Power-on.....	12
Chapter Four Operation Guide	13
1. Block.....	13
2. How to run a single-block PCR program	14
2.1. How to edit PCR programs.....	16
2.2 How to set system parameters	20
3. How to run a double- block PCR program.....	22
3.1 How to edit a PCR program.....	23
3.2 How to set system parameters	26
4. How to run a gradient block PCR program.....	27

4.1 How to edit a PCR program.....	28
4.2 How to set system parameters.....	31
4.3 Characteristics of Temperature Distributing of Gradient Block.....	31
5 How to Input and Output the PCR Program	32
5.1 Connect Usb Flash Memory	32
5.2 Input file from usb flash memory	33
5.3 Export file to usb flash memory	34
Chapter Five Connection of Computer	36
1. Software installation.....	36
2. Online setup	36
3. Software installation.....	36
4. Configure your equipment.....	38
4.1 Network Connection	38
4.2 Network Enable Administrator.....	39
4.3 Configure	40
5. Main interface.....	44
6. Toolbar	45
7. Basic manipulation.....	45
8. User manual.....	48
9. File menu	50
10. Tool menu	55
Chapter Six Firmware Upgrade	58
1. Configure your equipment.....	58
2. How to Upgrade the Software.....	58
Chapter Seven Failure Analysis and Troubleshooting.....	66
1. Failure Analysis and Troubleshooting.....	66
2. Spare Parts list.....	68
Appendix 1 Wiring Diagram.....	69
Appendix 2 Parameter Value & Meaning	70

Chapter One Introduction

This chapter briefly introduces PCR technique and its applications, PCR thermal cyclers, and the characteristics of BOECO TC-PRO Thermal Cycler.

1. Brief Introduction of PCR Technique

PCR (Polymerase Chain Reaction), or cell-free molecule cloning, is a technique for amplifying nucleic acids in vitro, emulating natural DNA replication process. The PCR technique, using two DNA strands to be amplified as template, and a pair of synthetic oligonucleotides as primers, rapidly reproduces the specific DNA pieces under the catalysis of a thermostable DNA polymerase. Because of its simplicity, rapidity, specificity, and sensitivity, PCR has been widely applied to all fields of life sciences since its invention by Mullis in 1983 and the discovery of the thermostable DNA polymerase by Erlich in 1989. Great achievements have been obtained in PCR's applications in such areas as cytology, virology, oncology, genetics, forensics, and immunology. PCR technology is a milestone in the history of modern molecular biology.

2. PCR Applications

Research Areas	Gene cloning, DNA sequencing, mutation analysis, gene recombination and mutagenesis, identification and adjustment of DNA sequence of protein structure, detection of gene extension, construction of synthetic genes, construction of cloning and expression carrier, detection of polymorphism of a gene's inscribed enzyme;
Clinical Diagnoses	Bacteria (spirochaeta, rickettsia, diphtheria bacillus, colon bacillus, dysentery bacillus, and clostridium); Virus (HTLV, HIV, HBV, HCV, HPVS, EV, CMV, EBV, HSV, measles virus, rotiform virus, B19 virus, and Lhasa virus); Parasite (malaria); Human hereditary diseases (Lesh-Nyhan syndrome, hemophilia, BMD, and DMD);
Immunology	HLA locus typing, qualitative analysis of T-cell receptor or antibody diversification, immune body gene mapping, quantitative analysis of lymph genes;
Human Genome Project	Identification of DNA markers using discrete repetitive; Sequence, construction of a genetic linkage map (detection of DNA, polymorphism, or semen mapping); Construction of a physical map, sequencing, and map expression;

Forensics	Specimen analysis in the venue, and HLA-DQ α locus typing;
Oncology	Pancreas cancer, rectum cancer, lung cancer, thyroid gland cancer, melanin cancer, and leukemia;
Social and Colony Biology	Genetic species research, evolution research, animal protection research, ecology, environmental sciences, and experimental genetics;
Paleontology	Specimen analysis in archeology and museum;
Biology	Diagnosis of animal hereditary diseases and detection of plant pathogeny.

3. Features of BOECO TC-PRO

BOECO TC-PRO Thermal Cycler is a PCR detection system with multiple functions. It has features and characteristics as followings:

- Provide five kinds of interchangeable block units to meet various PCR experiments' requirements;
- Adopting American ITI advanced thermoelectric cooling technology and thermoelectric cooling components manufactured under Japanese quality controlling mode, BOECO TC-PRO Thermal Cycler possess the stable and reliable performance;
- With speedy temperature ramping rate at the maximum of 4°C/S, BOECO TC-PRO can adjust ramping rate according to different experimental requirements;
- With multiple temperature-control modes, the instrument has much stronger compatibility;
- The central processor of BOECO TC-PRO Thermal Cycler can automatically distinguish block units, as well as run other relevant programs;
- With colourful extra large screen LCD and human-oriented operating interface, its operation becomes simple and clear
- It has the function of auto power off protection, and continues to complete the unfinished program after the power supply is resumed;
- Height and pressure of hot lid is adjustable so as to fit different reacting tubes on the basis of practical operating situations, in order to prevent reagents from the evaporation and pollution;
- RJ45 standard interface can be connected with normal computers, thus to achieve easy software upgrading.

4. Operations of BOECO TC-PRO

Adopting many advanced techniques, blocks of BOECO TC-PRO Thermal Cycler can meet different PCR experiments' requirements. It holds a leading position in the field of similar products.

BOECO TC-PRO Thermal Cycler Adaptation Carrier:



Standard Centrifuge
Tube 0.2ml

BLOCK 96G: 96×0.2ml (Gradient block)

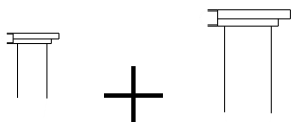

Standard Centrifuge Tube 0.2ml
+ Standard Centrifuge Tube 0.5ml

BLOCK 3048: 30×0.5ml+48×0.2ml

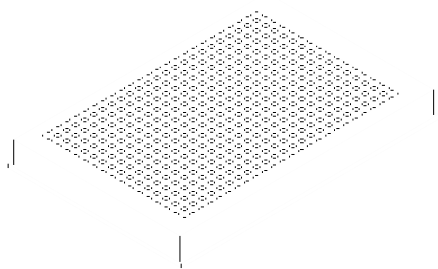

384-well plate

BLOCK 384G: 384-well plate (Gradient block)



BLOCK 48D: 48×0.2ml+48×0.2ml

Standard Centrifuge Tube 0.2ml × 2

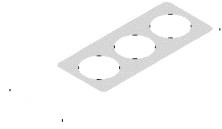

In Situ plate

BLOCK 4I: 4pcs. In Situ plate

Chapter Two Specifications

This chapter describes the Thermal Cycler's operation, transportation and storage conditions, basic parameters, performance and functions.

1. Normal Working Conditions

Ambient Temp.: 10°C ~ 30°C

Relative Humidity: ≤70%

Power Supply : ~100-240V 600W 50/60Hz

Note: Before power-on, please check whether the above working conditions are satisfied. Pay special attention to the power line's reliable grounding.

2. Conditions for Transportation and Storage

Ambient Temp.: -20°C ~ +55°C

Relative Humidity: ≤ 80%

3. Basic Parameters

Model	TC-PRO-96G	TC- PRO -3048	TC- PRO -384G	TC- PRO -48D	TC- PRO -4I
Model of Main Body	TC-E				
Model of Block	B-96G	B-3048	B-384G	B-48D	B-4I
Sample Capacity	96×0.2ml 96micro plate 12x8 strip tube 8x12strip tube	48×0.2ml+30×0.5 ml 8 Strip tube	384-well Plate	48×0.2ml+48×0.2 ml	4pcs. of In Situ plate
Temp. Range	4°C ~ 99°C				
Heating Rate(max)	≥4.0°C	≥2.8°C	≥2.8°C	≥4.0°C	≥1.8°C
Cooling Rate(max)	≥4.0°C	≥2.8°C	≥2.8°C	≥4.0°C	≥1.8°C

Temp. Uniformity	$\leq \pm 0.4^{\circ}\text{C}$ (95 $^{\circ}\text{C}$)				
	$\leq \pm 0.3^{\circ}\text{C}$ (72 $^{\circ}\text{C}$)				
	$\leq \pm 0.3^{\circ}\text{C}$ (55 $^{\circ}\text{C}$)				
Temp. Accuracy	$\leq \pm 0.3^{\circ}\text{C}$				
Max. Gradient	30 $^{\circ}\text{C}$	/	30 $^{\circ}\text{C}$	/	/
Min. Gradient	1 $^{\circ}\text{C}$	□	1□	□	□
Set temp. range of hotlid	30□ ~ 110□				
Dimension	470mm×340mm×260mm (L×W×H)				
Weight (kg)	10				
Fuse	250V 8A $\Phi 5 \times 20$				
PC Interface	RJ45				

Note: When temperature set value of hot-lid is lower than that of block, the temperature of hot-lid showed in the display would be higher than the set value.

4. Performances

Maximum number of cycles: 99

Maximum number of sections: 5

Maximum procedures within a cycle: 16

Number of programs: 99

Noise: 59dB (Background Noise: below 40dB testing on 1m dead ahead)

5. Software Functions

File editing and saving

File accessing, modifying and deleting

Adjusting the heating/cooling rate automatically

Automatic temperature & time increments/decrements during cycling program execution

Displaying the data at each phase of program execution instantly

Pause of program running
Stop of program running
Auto-restart in case of power failure
Soft upgrading via RJ45 interface
Sound alarm
Estimating total program execution time and remaining program running time
Date and time (year, month, day, hour, minute, second) display and calibration
Failure protection and alarming

Note: The above software functions are for reference only. The Boeckel + Co (GmbH + Co) KG reserves the right to modify the software functions without notice.

Chapter Three Preparations

This chapter introduces the BOECO TC-PRO Thermal Cycler's mechanical structure, the keyboard and each button's functions, and some preparations before power-on. Before any operation, please read this chapter carefully and make sure you are familiar with the steps introduced.

1. Structure Description

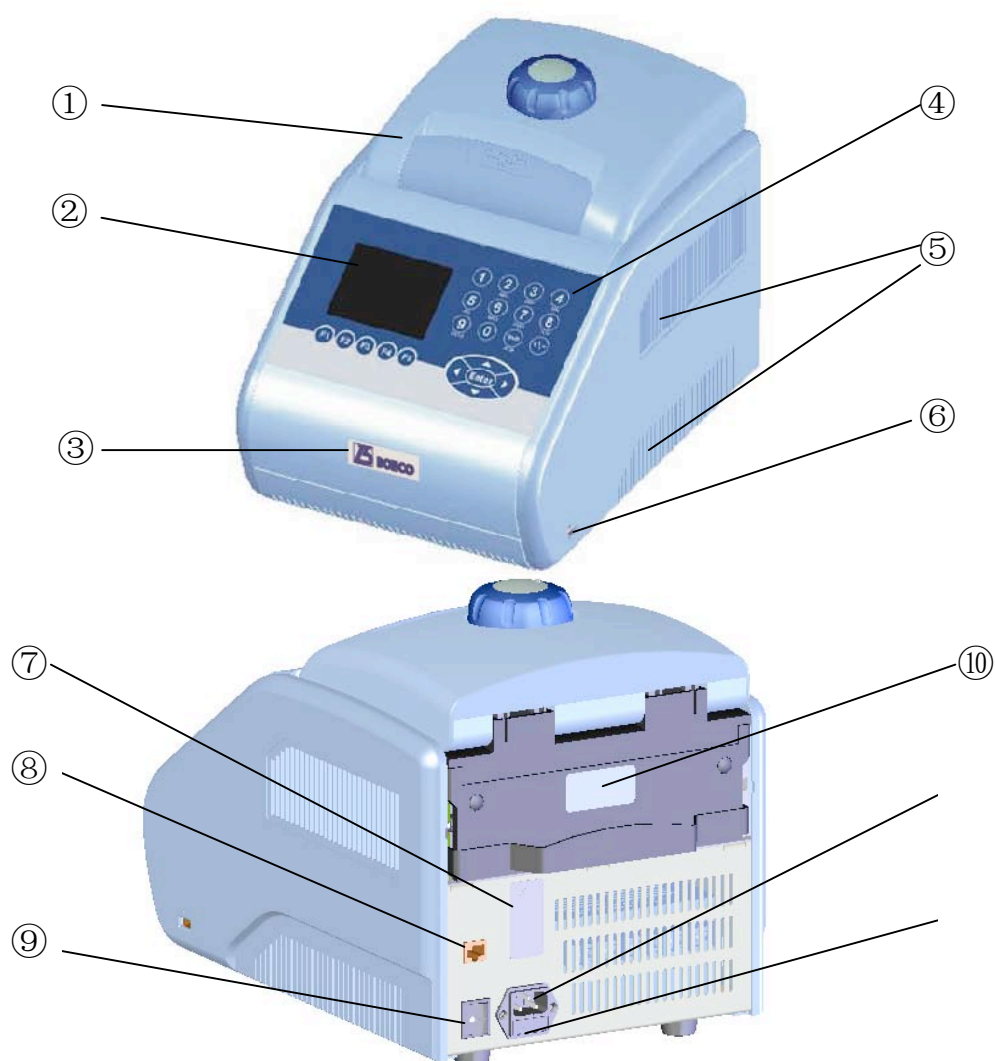

- | | | |
|------------------------|--------------------|-----------------|
| ① Block | ② LCD Display | ③ Logo |
| ④ Keyboard | ⑤ Ventilating Hole | ⑥ USB interface |
| ⑦ Sticker of Main body | ⑧ RJ45 interface | ⑨ Switch |
| ⑩ Sticker of Block | ⑪ Power Socket | ⑫ Fuse Socket |

Notes: The fuse specifications are as follows: 250V 8A, $\Phi 5 \times 20$ mm. The fuse should be replaced by one that meets those specifications. If you need certificated fuses, please contact the distributor or manufacturer.

2. Keyboard Diagram

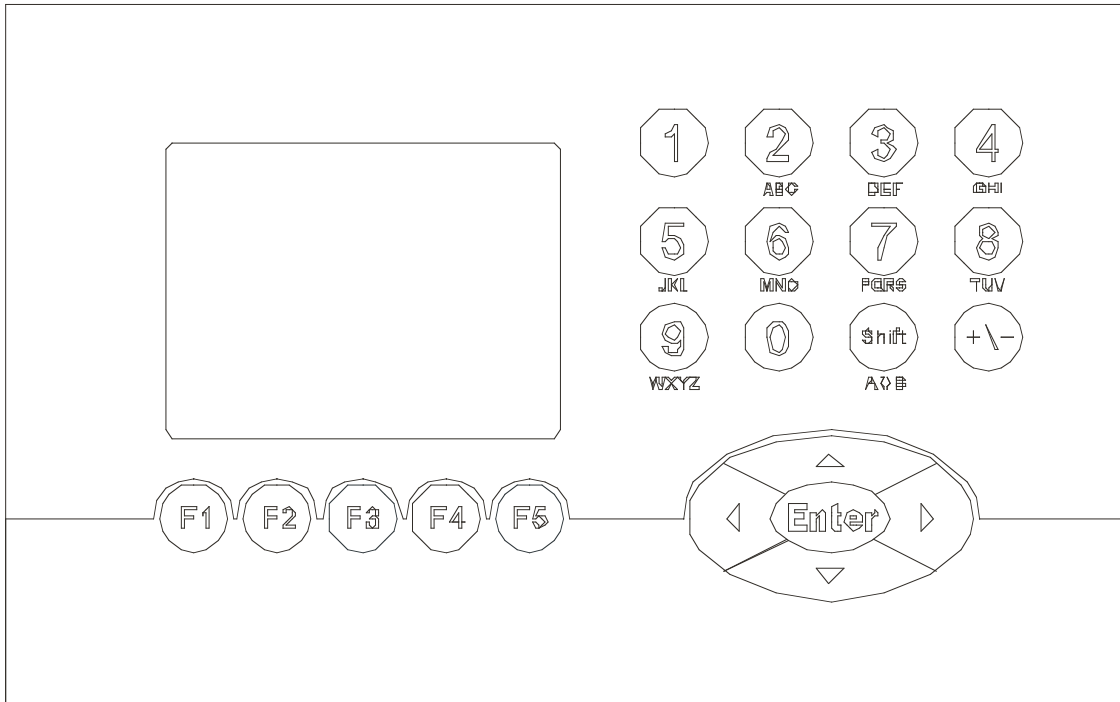

3. Keyboard Instructions



“Digit & Letter”, select the letter by pressing in succession.



“Shift”, shift from one block to another



“Function”, change “+ , -” when editing process temperature and modifying time

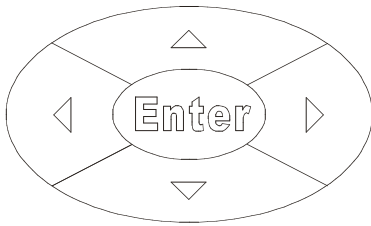

“Right/Left”, moving the cursor one position to the left or right when pressing during file parameter setting.

“Up/Down”, moving the cursor one position to the up or down when pressing during file parameter setting.

“Enter”, press it to accept the present parameters setting displayed on the screen when setting documents.



“Menu”, press any button to accept the current items displayed above the button..

4. Installation of Block Unit

The main unit must link with the block unit so as to work normally. Please install or dismantle the block unit according to the following steps:

4.1 Installation steps

- a) Put the block onto the slot of main body, uplift the locking handle, and push the block slowly until the locking handle is in the right place.
- b) Press the locking handle downwards, thus the block will move forwards automatically. The sound “kaka” means that the block is installed in the right place.
- c) Power-on and the instrument can run normally.

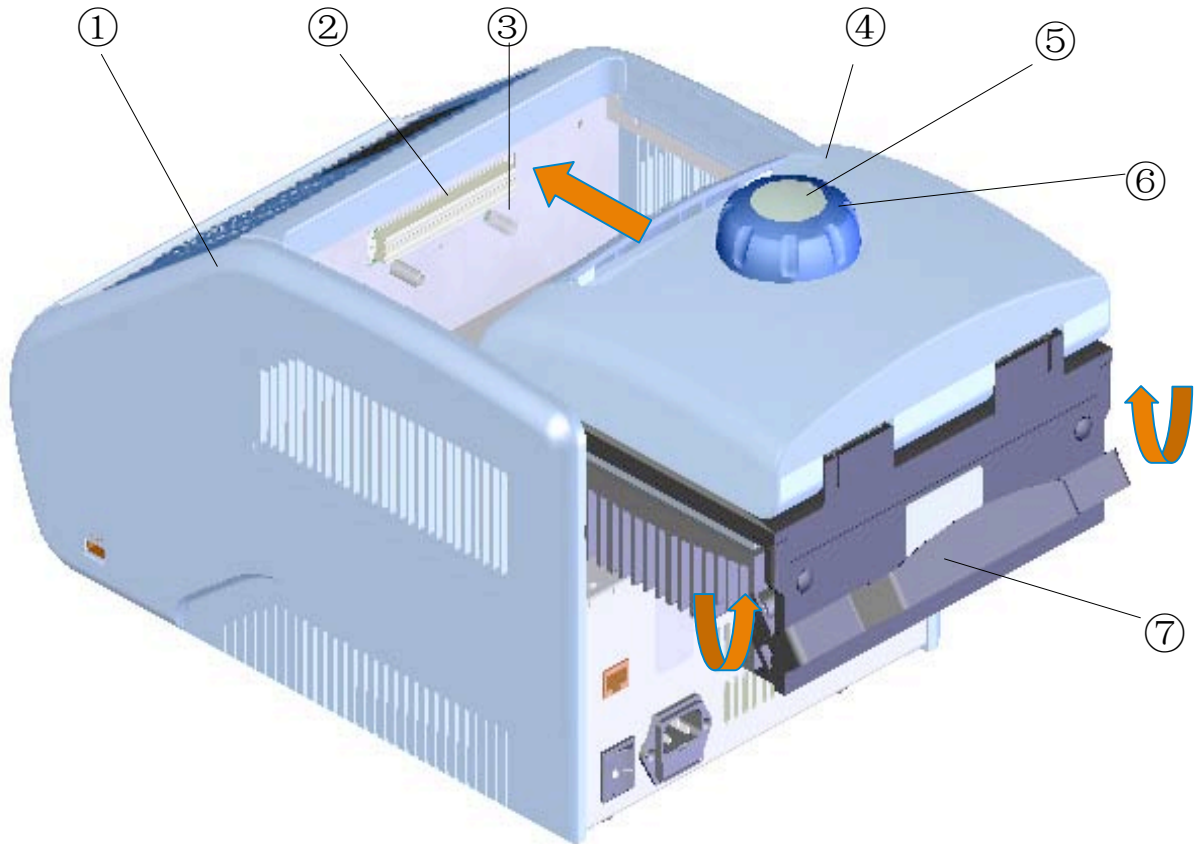

- | | | | |
|---|--|---|--------------------------------|
| <input type="checkbox"/> Main Body | <input type="checkbox"/> Main Unit Connecting Plug | <input type="checkbox"/> Locating set | <input type="checkbox"/> Block |
| <input type="checkbox"/> Unlocking Device | <input type="checkbox"/> Rotator | <input type="checkbox"/> Locking Handle | |

-
- Note:**
1. Make sure to switch off the power supply before installing block.
 2. When install block, please pay close attention to push the block slowly; Otherwise , the main unit connecting plug may be damaged.
 3. When uninstall block, please draw the block from the slot gently. It's forbidden to lean the block for fear of snap of connection wire.
 4. After installation, the block unit will be recognized by the main body automatically, and will be ready for work without any other operation.
-

4.2 Dismantlement Steps

- a) Power off firstly, make sure to dismantle or replace the block.
- b) Uplift the locking handle, it will sound “kaka”, and the block will move backwards simultaneously.
- c) Take out the block through the locking handle. The dismantlement is finished.

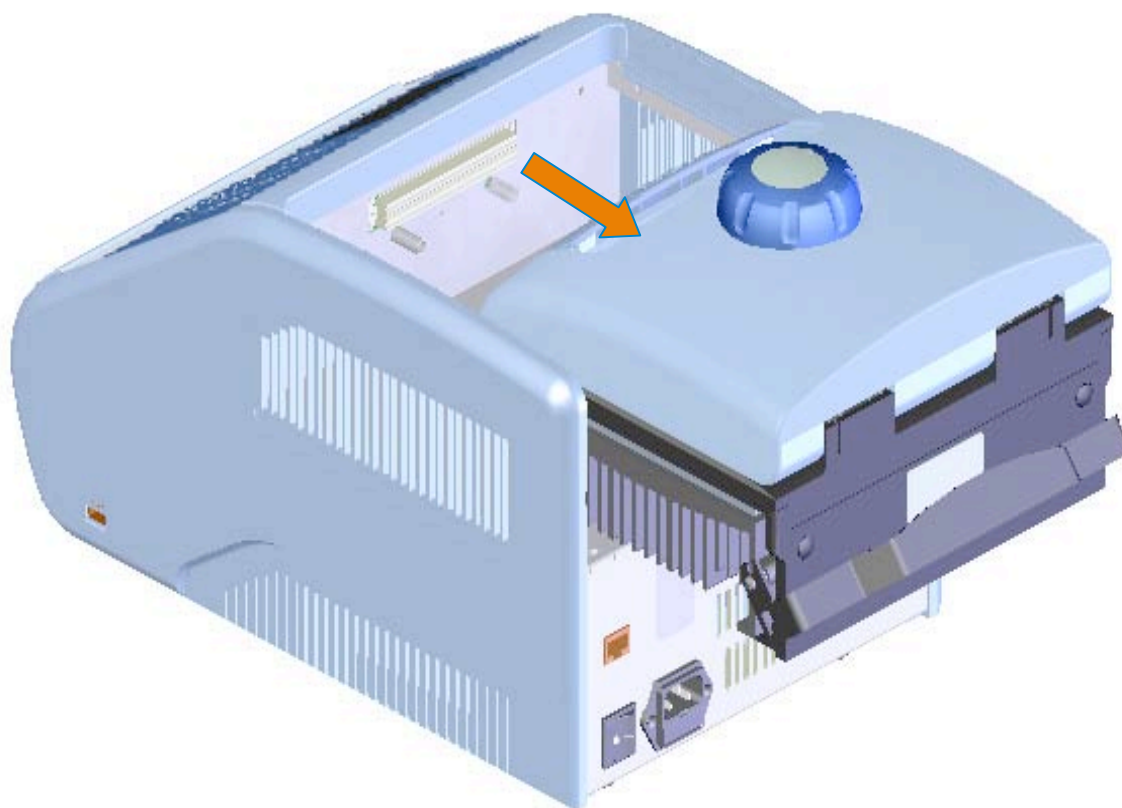

5. Inspections before Power-on

Before switch the power on, please ensure that:

- 1) Supply voltage falls within the specified limits (refer to Chapter Two);
- 2) The plug has been inserted into the power socket reliably;
- 3) The grounding of the power line is reliable.

6. Power-on

Turn on the power (i.e. turn the power switch to position “-”), the BOECO TC-PRO Thermal Cycler will beep twice, and the fan start to running, which means the instrument is power-on.

At this time, the LCD will display “**Self testing** •••••”, which means the instrument is under self-testing. It will last for about 1-2 minutes. Please wait patiently. After the self-testing, the main menu will be displayed, and the instrument is ready for operations such as editing, accessing, modifying, or deleting a PCR amplification file.

Chapter Four Operation Guide

There are five kinds of block units suitable to BOECO TC-PRO Thermal Cycler. In this chapter, we will explain in details on operations of every kind of block unit, for example, how to edit, access, modify, delete, or run a PCR amplification file, how to set parameters under different block unit.

Warning! Please turn off the power immediately and contact the distributor if abnormal sound or display appears after power-on, or if failure alarm and display are found in the process of the device's self-testing.

Note: If the number of samples is less than the number of conical holes of the block, the sample tubes should be evenly distributed over the block, in order to ensure that the heated lid will stably press on the top of the sample tubes, so that both the block's load and the temperature distribution in each tube are even.

Note: Before closing the cover, please revolve the knob counter-clockwise according to the knob diagram till there sound "dang, dang....." Please note that the knob can be tightened by revolving clockwise, but can be loosed by revolving counter-clockwise.
After closing the cover but before power on, please revolve the knob clockwise till it sound "dang,dang....." Revolve the knob one more turn.
At the beginning of revolving the knob clockwise or counter-clockwise, you can hear "dang,dang...." sound, press the unlocking device by your finger; meanwhile, revolve the knob counter-clockwise for two turns, thus to loose the unlocking device to revolve the knob.

1. Block

BOECO TC-PRO has five models with different purpose. And each model has its own running program.

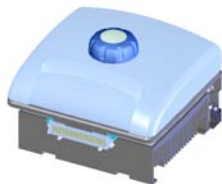

B96G
Gradient block program

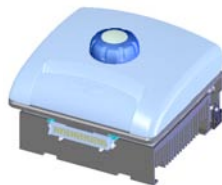

B3048
Mixed block program

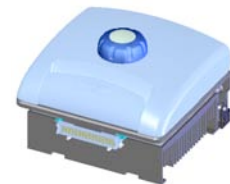

B384G
Gradient block program

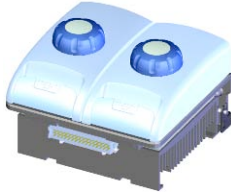

B48D
Dual-block program

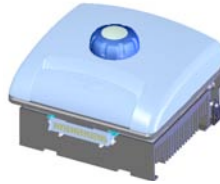

B4I
Single-block program

2. How to run a single-block PCR program

Switch the power on, BOECO TC-PRO Thermal Cycler will beep twice, and it means the power supply is connected well. The screen will display “**Self testing** ●●●●●”, and the instrument will carry on self testing. The self-testing needs about 1~ 2 minutes and please wait patiently. If the self-testing is successful, the screen will display the main interface.

On the left top of the main interface it displays the state of Hot lid.

On the central area it displays Boeckel + Co (GmbH + Co) KG information, software version number, block model, default file, default user, control mode and sample volume.

- ✧ Press “**File**” to enter into file list interface.
- ✧ Press “**System**” to enter into system parameter setting interface.
- ✧ If the current file doesn't have code, press “**Run**” to enter into running interface and tube mode confirmation; If the current Control Mode has code, press “**Run**”, thus the screen shows the following interface.

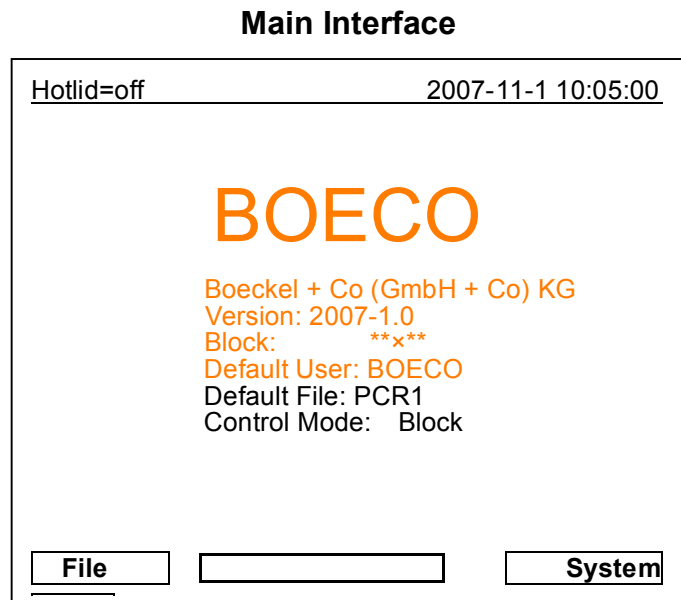

Main Interface

In this interface, press “**Number**” key to input code.

- ✧ Press “**Back**” to go back to the main interface.
- ✧ Press “Accept” key to confirm the code.
- ✧ If the module is mixed block, press “Accept” to determine the test-tube type; pop-up tube type selection dialog.
- ✧ If the module is not mixed block, the current Control Mode is Block mode and press “Accept” running into the file operation interface; If the current control mode is Tube mode, press “Accept” key, then pop-up tube vol. Settings dialog box.

Hot lid=off	2007-11-1
10:05:00	
BOECO	
Boeckel + Co (GmbH + Co) KG	
Version: 2007-1.0	
Block: **x**	
Default User: BOECO	
Default File: PCR1	
Control Mode: Tube	
<input type="text" value="Input password"/>	

Tube style selection

In this interface press **+/-** can choice the actual tube type.

- ✧ Press “Back” key to go back to the main interface.
- ✧ Press “next”. If the current control mode is Block Mode, click “next” to enter document operation interface; if the current mode is Tube Mode, press “next” key pops up the following interface.

Hotlid=off	2007-11-1 10:05:00
BOECO	
Boeckel + Co (GmbH + Co) KG	
Version: 2007-1.0	
Block: **x**	
Default User: BOECO	
Default File: PCR1	
Control Mode: Tube	
<input type="text" value="Select Tube Type"/> 0.2ml	
<input type="button" value="Usblink"/>	<input type="button" value="Back"/> <input type="button" value="next"/>

In this interface, press “**Character**” key to input number of sample volume (Unit: Micro liter) according to the practicality. Under Tube Mode, samples with different concentrations have different overshooting temperature and duration time.

- ✧ Press “**Back**” to go back to the main interface.
- ✧ Press “**Run**” to enter into file running interface.

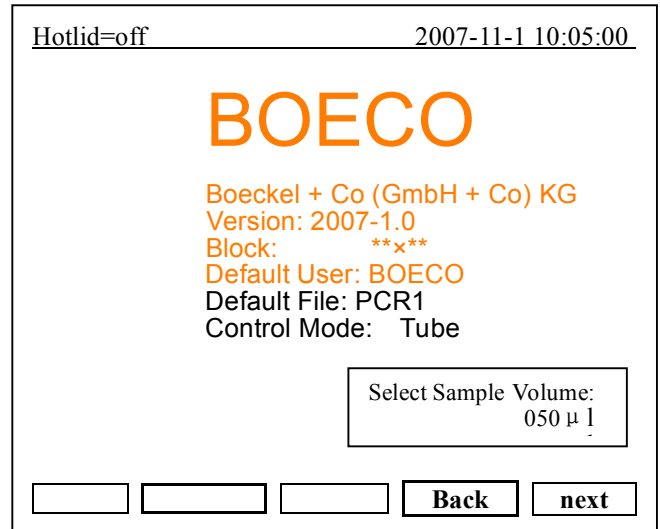

2.1. How to edit PCR programs

Press “**File**” on the main interface to enter file list interface. There are 3 files listed in the form as showed in the picture. When the flashing bar is flashing in the User Column, select users through pop-up key; at this time, the File Name Column will display the relative files of the selected user dynamically. Shift to the File Name Column, where the flashing bar will flash, then select relative user’s file through pop-up key.

- ✧ Press “**Edit**” to edit the file indicated by the cursor.
- ✧ Press “**New File**” to edit a new file.
- ✧ Press “**Delete**” and the system will alarm “Confirm delete file?”, then according to the alert to select (Delete) or (BACK).
- ✧ If the current file doesn't have code, press “**Run**” to enter into File Running Interface and tube type confirmation; If the current file has code, press “**Run**”, thus there appears a dialog box.

File List Interface

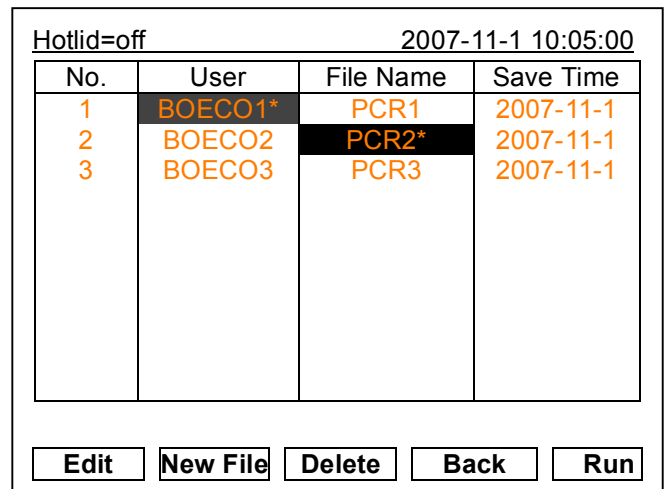

Input Password:
 -

- ✧ If the module is mixed block, determine the test-tube type first; pop-up the following dialog

box.

Select Tube Type
0.2ml

- ✧ If the current Control Mode is block mode, press "Run" running into the file operation interface; If the current control mode is Tube mode, press "Run" key, then pop-up the following dialog box.

Select Sample Volume:
050 μ l

The same as main interface, user could input the actual password, sample type and number of sample volume (Unit: Micro liter) according to the practicality

Note: The sign "*" at the top of User and File indicates the current running file is default one, which can be modified in the parameter setting interface.

File Edit Interface

In this interface, you can edit sections and segments of the file. A File is comprised by sections and segments. And the sections contain many segments, which you can set cyclers to be run (refer to the figure). Move cursor by pressing "Up/Down" and "Right /Left", and the position that the cursor reaches will be displayed in white on a black background. Press "Digit&Letter" to modify parameter settings. Press "Function" to change +/-.

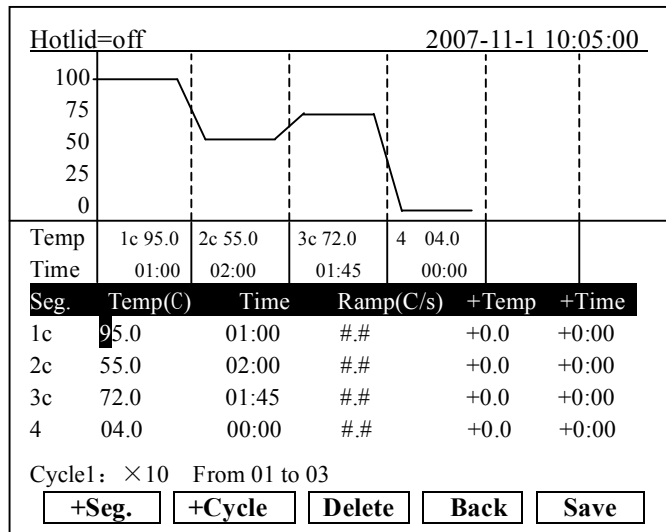

- ✧ Press "+Seg." to enter into segment edit interface. In every segment, the user can set setting temperature (Temp.), duration (Time), Ramping rate (Ramp), temperature increment of every cycler(+Temp) and time increment of every cycler (+Time). Press "Delete" to delete the present segment
- ✧ Press "+Cycle" to enter into segment edit interface, where the user can set cycle numbers and initial cycle segment. The figure shows a cycle from the first segment to the third one, and there are totally 10 times cycles.
- ✧ Press "+Cycle" repeatedly to add sections (max.: 5 sections). Press "Delete" to delete the current segment. Move cursor by pressing "Up/Down" to enter into the former segment or

the latter.

- ◇ Press “**Save**” to enter into file save interface.
- ◇ Press “**Back**” to go back to File List Interface.

Special Warning:

1. For the new edited PCR program, please save first and then run it, otherwise the file file can't be run;

2. When setting “Time” as “--:--”, the hot lid will be closed automatically in the case that the block controls the temperature.

Relation of sections and segments in a

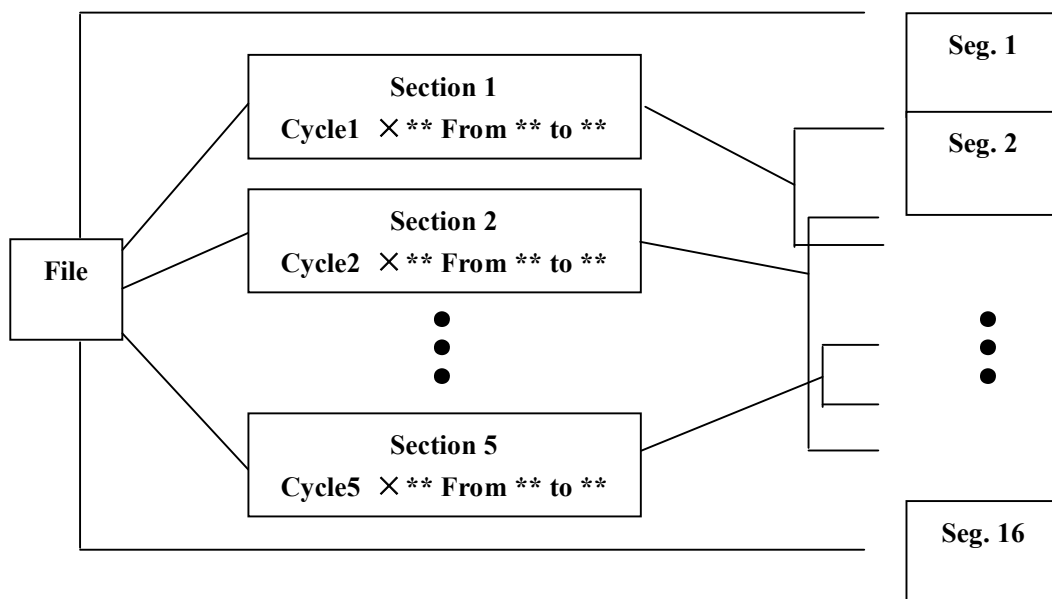

In this interface press “**Digit&Letter**” to input the file name. Press “**enter**” to move the cursor forwards one position. Select User and File Name through pop-up key. Click left button to delete characters while clicking right button to move the cursor. Press “**Caps**” key to shift the capital or small letter, and there will be a capital or small letter indication on the left top of the screen. (As ) showed in the above picture)

File Save Interface

Hotlid=off	2007-11-1 10:05:00
abc	
User:	R1
File Name:	R1
Password:	****
Password Check:	****
<input type="button" value="Main"/> <input type="button" value="Caps"/> <input type="button" value="Save"/> <input type="button" value=""/> <input type="button" value="Run"/>	

- ✧ Press “**Main**” to go back to the main interface.
- ✧ Press “**Save**” to save the file. When the file is normally saved, the system will remind “File have been saved. Please continue another operation”. Press “Enter” key to cancel the reminding bar. If the file was used, the system will remind you to rename (Rename) or continue to save (Save).
- ✧ Password setting press number memory.
- ✧ If the module is mixed block, determine the test-tube type first; pop-up the following dialog box.

Select Tube Type 0.2ml

- ✧ If the current Control Mode is block mode, press "Run" running into the file operation interface; If the current control mode is Tube mode, press "Run" key, then pop-up the following dialog box.

Select Sample Volume: 050 μ l

The same as main interface, user could input the actual password, sample type and number of sample volume (Unit: Micro liter) according to the practicality.

-
- Note:**
- 1 No difference between big and small letter, in setting file name and user name.
 - 2 Please remember the setting password.
 - 3 **Setting the password as 0~9 number character.**
-

File Running Interface

During normal running of a file, it will be flashing at the position of “Now Running...”. When the file is running over, the system will alarm “File run over”.

- ✧ Press “**Stop**” and it will remind “Confirm stop running?”.
- ✧ Please select “**Stop**” or “**Start**” according to the reminding information.
- ✧ Press “**Pause**” and it will remind “Now pause running?” According to the reminding information the user can select “**Start**” to continue. If the user doesn’t make a decision within 100 seconds, the system will continue running automatically.
- ✧ Press “**View File**” to view edited PCR programs.
- ✧ Press “**Skip**” to stop current temperature segment and run the next.

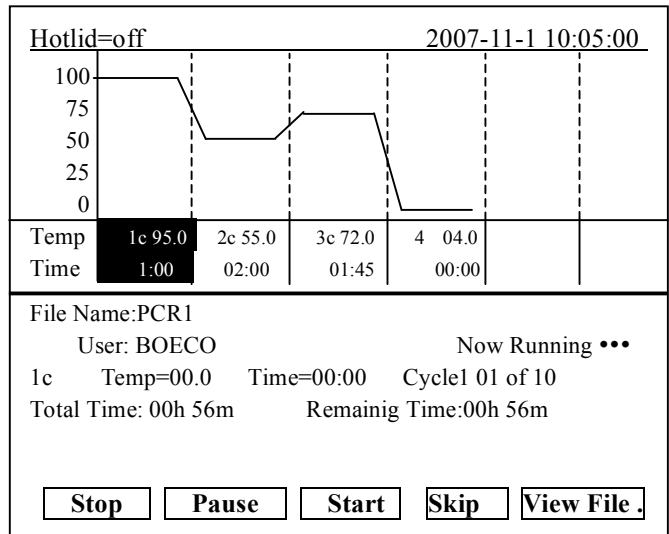

2.2 How to set system parameters

In the main interface press “**System**” to enter into system parameter setting interface.

Press “**Enter**” to move the cursor to the next item. The option is followed by the symbol “↕”. Press “**Up/Down**” to roll the option for selecting, and other information can be input by pressing “**Digit&Letter**”. Press “**Right/Left**” to move cursor’s position.

- ✧ Press “**Back**” to go back to the main menu.
- ✧ Press “**Save**” to save parameters.

Special Reminding: When set the parameter, please press the “Save”, otherwise the parameter remains the original one.

System Parameter Setting Interface

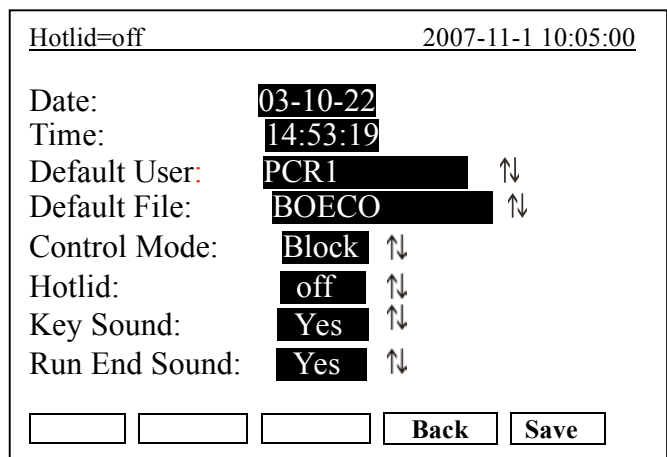

2.2.1 “Date”, “Time” state the default system time after power-on.

2.2.2 “Default File”, “Default User” state the default running program and the default user name.

2.2.3 “Control Mode” states the default control mode, including two optional modes as “Block” and “Tube”.

“Block” mode subjects to simple temperature control during the course of cooling & heating only. Compared to the block, cooling & heating rate of reagent is a little slower, therefore, the actual change of reagent’s temperature is different from the setting procedure. The actual time for reagent to reach & keep the setting temperature is far shorter than the setting time. (Please refer to the following figure: relation between block temperature and reagent temperature)

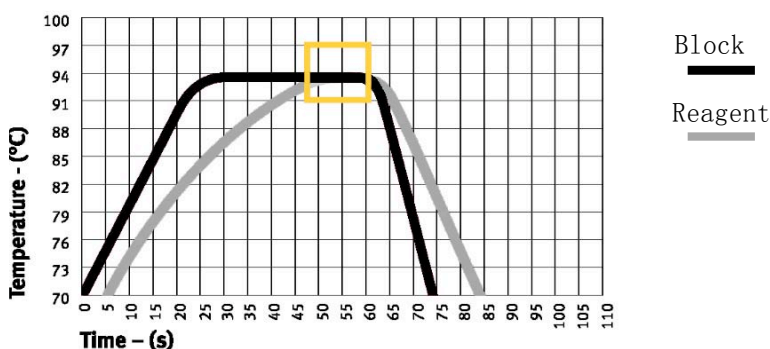

“Tube mode” has considered the phenomenon that the cooling & heating rate is a little slower than that of block. There is an overshoot after reaching the setting temperature, which can allow reagent to reach the setting temperature faster. During the same setting time as “Block”, the actual time for reagent to keep the setting temperature is prolonged obviously. (Please refer to the following figure: relation between block temperature and reagent temperature)

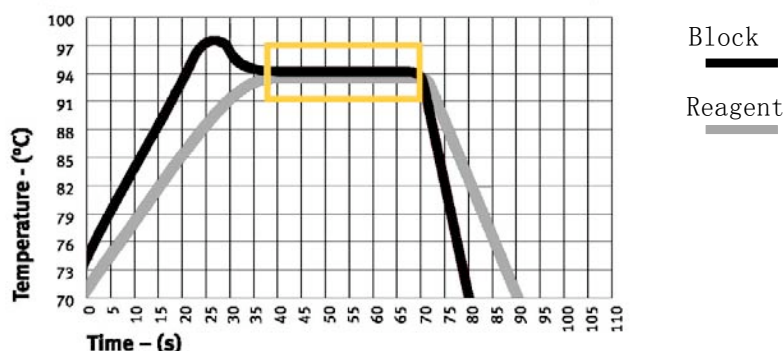

2.2.4 “Hotlid” stand for the state of hotlid “Open” or “Close”.

2.2.5 “Key Sound”, “Run End Sound” stand for the sound of pressing key and reminding sound after the procedure runs over respectively.

See details in the APPENDIX 2.

- NOTE:**
1. After set the parameters, please press “Save” to confirm the setting, otherwise the parameter remains the original one.
 2. Before the instrument leaves the factory, its inside clock has been adjusted in accordance with Beijing Time.
 3. For the first use of the instrument, you are advised to confirm whether the date and clock time are set right as local time.

3. How to run a double- block PCR program

Switch the power on, BOECO TC-PRO Thermal Cycler will beep twice, and it shows the power supply is connected well. The screen will display “Self testing ●●●●●”, and the instrument will carry on self testing. The self-testing needs about 1~2 minutes, and please wait patiently. If the self-testing is successful, the screen will display the main interface.

Dual block means two blocks: Block A and B respectively represent actual block on the left and right. Press “Shift” to operate A or B blocks in the same interface. The following introduction takes the example of operating A block

In the top center of the main interface, it displays the current operating block. As in the illustration it shows the control symbol is “A”. Press “Shift” to change control symbol. In the central area of the main interface it displays the types of A & B blocks, default file, default user, control mode and sample volume.

If the current Control Mode is Block mode, press “Run” to enter into the File Running Interface; While if the current Control Mode is Tube mode, press “Run” and thus the following dialog box will appear:

- ◇ Press “File” to enter into the File List Interface.
- ◇ Press “System” to enter into System Parameter Setting Interface.
- ◇ If the current file doesn't have code, press “Run” to enter into File Running Interface and tube type confirmation; If the current file has code, press “Run”, thus there appears a dialog box.

The Main Interface

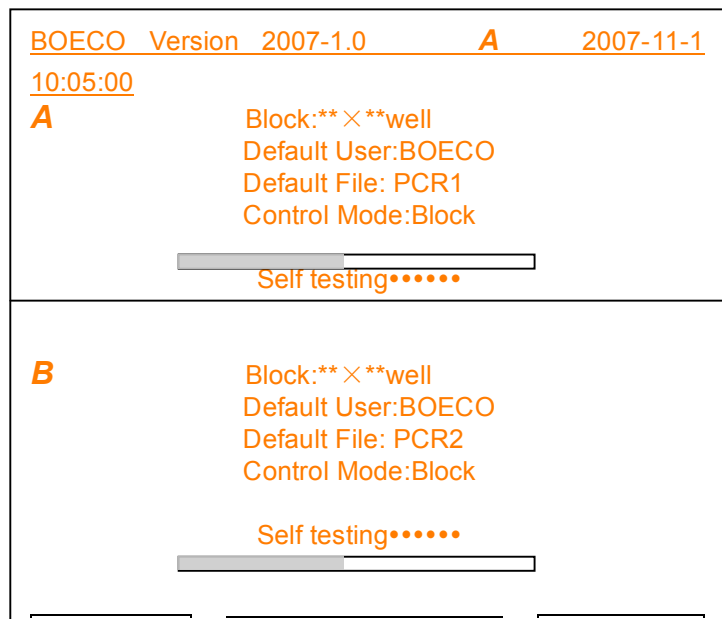

Select Sample Volume:
050 μ l

The same as single module. Press **“Back”** to go back to the main interface. Press **“Accept”** key to confirm the code.

- ✧ If the current Control Mode is block mode, press **“Run”** running into the file operation interface; If the current control mode is Tube mode, press **“Run”** key, then pop-up the following dialog box.

Select Sample Volume:
050 μ l

The same as single module, user could input the sample volume (Unit: Micro liter) according to the practicality. Press **“Back”** to go back to the main interface. Press **“Run”** key to to enter into file running interface.

3.1 How to edit a PCR program

File List Interface

In the main interface press **“File”** to enter into File List Interface. There are 3 files listed in the form as showed in the picture. When the flashing bar is flashing in the User Column, select users through pop-up key; at this time, the File Name Column will display the relative files of the selected user dynamically. Shift to the File Name Column, where the flashing bar will flash, then select relative user's file through pop-up key.

BOECO Version 2007-1.0 <i>A</i> 2007-11-1 10:05:00			
No.	User	File Name	Save Time
1	BOECO1*	PCR1	2003-11-1
2	BOECO2	PCR2*	2003-11-1
3	BOECO3	PCR3	2003-11-1

B Block: **x**well
 Default User: BOECO
 Default File: PCR2
 Control Mode: Block

Edit
New File
Delete
Back
Run

- ✧ Press **“Edit”** to edit the file indicated by the cursor.
- ✧ Press **“New File”** to edit one new file.
- ✧ Press **“Delete”** and the system will alarm **“Confirm delete file?”**, then according to the alert information to select (Delete) or (BACK) .
- ✧ Press **“Back”** to go back to the main interface.
- ✧ If the current file doesn't have code, press **“Run”** to enter into File Running Interface and tube type confirmation; If the current file has code, press **“Run”**, thus there appears a dialog box.

Input Password

The same as single module. Press **“Back”** to go back to the main interface. Press **“Accept”** key to confirm the code. If the current Control Mode is block mode, press **“Run”** running into the file operation interface; If the current control mode is Tube mode, press **“Accept”** key, then pop-up tube vol. Settings dialog box.

- ✧ If the current Control Mode is Block mode, press “Run” to enter into the File Running Interface; while if the current Control Mode is Tube mode, press “Run” and thus the following dialog box will appear:

Select Sample Volume:
 050 μ l

The user can input Sample Volume (Unit: Micro liter) by the same way as that of the main interface. Press “Back” to go back to File List Interface; Press “Run” to enter into file running interface.

NOTE: The sign“*”at the top of User and File indicates the current running file is default one, which can be modified in the parameter setting interface.

In this interface move the cursor by pressing “Up/Down” and“Right/Left”, and the position that the cursor reaches will be displayed in white on a black background. Press “Digit&Letter” to modify parameter settings. Press “Function” to change +/-.

- ✧ Press “+Seg.” to enter into the Segment Edit Interface. In every segment, you can set setting temperature (Temp.), duration (Time), Ramping rate (Ramp), temperature increment of every cycler(+Temp) and time increment of every cycler (+Time). Press “Delete” to delete the present segment.

File Edit Interface

BOECO Version 2007-1.0 A 2007-11-1 10:05:00

Seg.	Temp(C)	Time	Ramp(C/s)	+Temp	+Time
1c	95.0	01:00	##	+0.0	+0:00
2c	55.0	02:00	##	+0.0	+0:00
3c	72.0	01:45	##	+0.0	+0:00
4	04.0	00:00	##	+0.0	+0:00

Cycle1 : ×10 From 01 to 03

B Block: **x**well
 Default User: BOECO
 Default File: PCR2
 Control Mode: Block

+Seg.
+Cycle
Delete
Back
Save

- ✧ Press “+Cycle” to enter into Section Edit Interface, where you can set cycle numbers and initial cycle segment. The figure shows a cycle from the first segment to the third one, and there are totally 10 times cycles.
- ✧ Press “+Cycle” repeatedly to add sections (max.: 5 sections). Press “Delete” to delete the present segment. Move the cursor by pressing “Up/Down” to enter the former segment or the latter.
- ✧ Press “Save” to enter file save interface.
- ✧ Press “Back” to go back to the File List Interface.

Special Warning:

1. For the new edited PCR program, please save first then run it, otherwise the file cannot be run.
2. When setting "Time" as "--:--", the hot lid will be closed automatically when the block reaches the target temperature

In this interface press "**Digit&Letter**" to enter the file name. Press "**Enter**" to move the cursor forwards one position. Select User , File Name and Password through pop-up key. Click left button to delete characters while clicking right button to move the cursor. Press "**Caps**" to shift the capital or small letter, and there will be a capital or small letter indication on the left top of the screen. (As the example: **Abc**).

- ✧ Press "**Main**" to go back to the main interface.
- ✧ Press "**Save**" to save the file. When the file is normally saved, the system will remind "File have been saved. Please continue another operation", Press enter key to cancel the reminding bar. If the file was used, the system will remind you to rename (Rename) or continue to save (Save).
- ✧ If the current Control Mode is Block mode, press "**Run**" to enter into the file running interface; while if the current Control Mode is Tube mode, press "**Run**" and thus the following dialog box will appear:

File Save Interface

BOECO Version 2007-1.0 **A** 2007-11-1 10:05:00

Abc

User: **BOECO**

File Name: **R1**

Password: ********

Password Check: ********

B

Block: **×**well
 Default User: BOECO
 Default File: PCR2
 Control Mode: Block

Select Sample Volume:
050 μ l

The user can input Sample Volume (Unit: Micro liter) by the same way as that of the main interface. Press "Back" to go back to File List Interface; Press "Run" to enter into the file running interface.

Note: Setting the password as 0~9 number character.

After the file is running over, the system will remind "File run over".

- ✧ Press "**Stop**" and it will remind "Confirm stop running?". According to the reminding information to select "STOP" or "START".
- ✧ Press "**Pause**" and it will remind "Now pause running?" According to the reminding information you can select "START" to continue. If you don't make a decision within 100 seconds, the system will continue running automatically.
- ✧ Press "**View File**" to view edited PCR programs.
- ✧ Press "**Skip**" to stop current temperature and run the next.

File Running Interface

BOECO Version 2007-1.0				A	2007-11-1 10:05:00
File Name: PCR1			User: BOECO		
Seg. 1	Temp(C)	Time(m:s)	Cycle1		
PV	32.6	00:00	01		
SV	95.0	01:00	01		
Total Time:00h 00m Remain Time: 00h 00m Hotlid=042C					
B Block: **×**well					
Default User: BOECO					
Default File: PCR2					
Control Mode: Block					
<input type="button" value="Stop"/>		<input type="button" value="Pause"/>		<input type="button" value="Start"/>	
		<input type="button" value="Skip"/>		<input type="button" value="View File"/>	

3.2 How to set system parameters

In the main interface press "**System**" to enter system parameter setting interface.

Press "**Enter**" to move the cursor to next item. The option is followed by the symbol "↕". Press "**Up/Down**" to roll the option for selecting, and other information can be entered information by pressing "**Digit&Letter**". Press "**Right/Left**" to move the cursor's position.

- ✧ Press "**Back**" to go back to the main menu.
- ✧ Press "**Save**" to save the parameters.

System Parameter Setting Interface

BOECO Version 2007-1.0				A	2007-11-1 10:05:00
Default User: BOECO			↕		
Default File: PCR1					
Control Mode: Block		↕		Date: 03-10-22	
Sample Volume: 050 μl				Time: 14:53:19	
Key Sound: Yes		↕		Hotlid: 105C	
Run End Sound: Yes		↕			
B Block: **×**well					
Default User: BOECO					
Default File: PCR2					
Control Mode: Block					
<input type="button" value="Back"/>		<input type="button" value="Save"/>			

Special Reminding:

When set the parameter, please press the "Save", otherwise the parameter remains the original one.

NOTE: After set the parameters, please press “Save” to confirm setting, otherwise the parameter remains the original one
 Before the instrument leaves the factory, its inside clock has been adjusted in accordance with Beijing Time
 For the first use of the instrument, you are advised to confirm whether the date and clock time are set right as local time.

4. How to run a gradient block PCR program

Switch the power on, BOECO TC-PRO Thermal Cycler will beep twice, and it shows the power supply is connected well. The screen will display “**Self testing** ●●●●●”, and the instrument will carry on self testing. The self-testing needs about 1~2 minutes, and please wait patiently. If the self-testing is successful, the screen will display the main interface.

Main Interface

On the left top of the main interface, the state of Hot lid is displayed. On the central area, basic information such as Boeckel + Co (GmbH + Co) KG information, software version number, block type, default file, default user, control mode and sample volume, are displayed.

- ✧ Press “**File**” to enter into the File List Interface.
- ✧ Press “**System**” to enter into the System Parameter Setting Interface.
- ✧ If the current file doesn't have code, press “**Run**” to enter into File Running Interface and tube type confirmation; If the current file has code, press “**Run**”, thus there appears a dialog box.

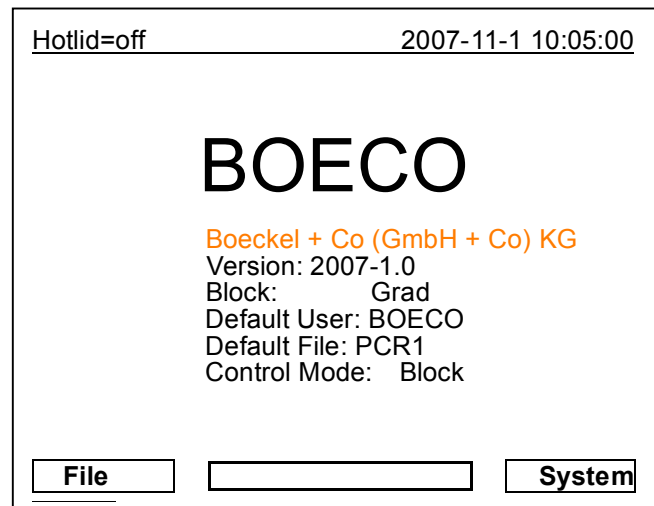

Input Password

The same as single module. Press “Back” to go back to the main interface. Press “Accept” key to confirm the code.

- ✧ If the current Control Mode is block mode, press "Run" running into the file operation interface; If the current control mode is Tube mode, press " Run" key, then pop-up tube vol. Settings dialog box.

Select Sample Volume:
050 μ l

4.1 How to edit a PCR program

Press **"File"** on the Main Interface to enter into the File List Interface, there are 3 files listed in the form as showed in the picture. When the flashing bar is flashing in the User Column, select users through pop-up key; at this time, the File Name Column will display the relative files of the selected user dynamically. Shift to the File Name Column, where the flashing bar will flash, then select relative user's file through pop-up key

- ✧ Press **"Edit"** to edit the file indicated by the cursor.
- ✧ Press **"New File"** to edit a new file.
- ✧ Press **Delete** and the system will alarm "Confirm delete file?", then according to alert to select (Delete) or (BACK) .
- ✧ Press **"Back"** to go back to the main interface.
- ✧ If the current Control Mode is Block mode, press **"Run"** to enter into the File Running Interface; While if the current Control Mode is Tube mode, press **"Run"**, thus the following dialog box will be displayed:

Select Sample Volume: 050 μ l

The user can input Sample Volume (Unit: Micro liter) by the same way as that of the main interface. Press **"Back"** to go back to File List Interface; Press **"Run"** to enter into the file running interface.

File List Interface

Hotlid=off		2007-11-1 10:05:00	
No.	User	File Name	Save Time
1	BOECO1	PCR1	2007-11-1
2	BOECO2*	PCR2*	2007-11-1
3	BOECO3	PCR3	2007-11-1

Edit **New File** **Delete** **Back**

Note: The sign "*" at the top of User and File indicates the current running file is default one, which can be modified in the parameter setting interface.

File Edit Interface

In this interface move cursor by pressing “Up/Down” and “Right/Left”, and the position that the cursor reaches will be displayed in white on a black background. Press “Digit&Letter” to modify parameter settings. Press “Function” to change +/-.

- ✧ Press “+Seg.” to enter segment edit interface. In every segment, you can set setting temperature (Temp.), duration (Time), Ramping rate (Ramp), temperature increment of every cycler (+Temp) and time increment of every cycler (+Time). Press “Delete” to delete the present segment.
- ✧ Press “+Cycle” to enter section edit interface, where you can set cycle numbers and initial cycle segment. The figure shows a cycle from the first segment to the third one, and there are totally 10 times cycles.
- ✧ Press “+Cycle” repeatedly to add sections (max.: 5 sections). Press “Delete” to delete the present segment. Move cursor by pressing “Up/Down” to enter the former segment or the latter.
- ✧ Press “Save” to enter file save interface.
- ✧ Press “Enter ” to check detailed gradient distributing situation. Please refer to the following picture:
- ✧ Press “Back” to enter file run interface.

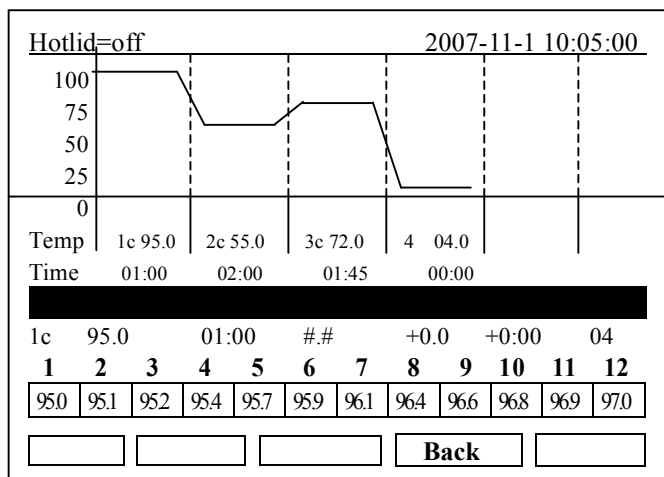
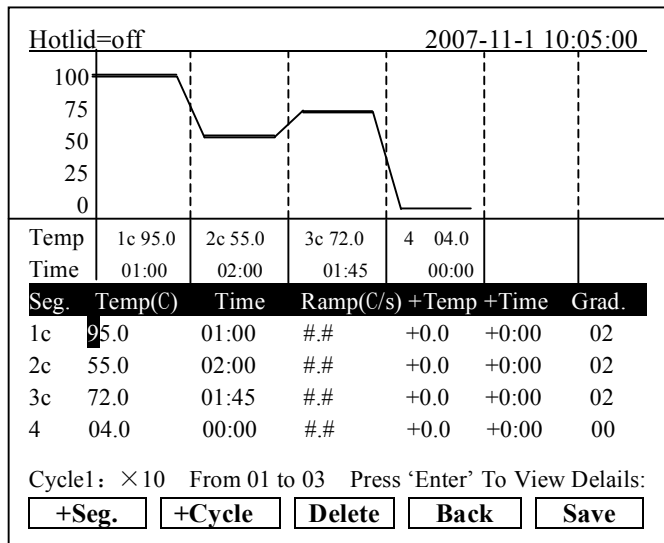

Special Warning:

1. For the new edited PCR program, please save first then run it, otherwise the file cannot be run.
2. When setting “Time” as “--:--”, the hot lid will be closed automatically when the block reaches the target temperature

In this interface press “**Right/Left**” to enter the file name. Press “**Enter**” to move the cursor forwards one position. **Select User , File Name and Password through pop-up key**. Click left button to delete characters while clicking right button to move the cursor. Press “**Caps**” to shift the capital or small letter, and there will be a capital or small letter indication on the left top of the screen. (as the example: ) .

- ✧ Press “**Main**” to go back to the main interface.
- ✧ Press “**Save**” to save the file. When the file is normally saved, the system will remind “File have been saved. Please continue another operation”, Press “**Enter**” to cancel the reminding bar. If the file was used, the system will remind you to rename (Rename) or continue to save (Save).
- ✧ If the current Control Mode is Block mode, press “**Run**” to enter into the File Running Interface; While if the current Control Mode is Tube mode, press “**Run**”, thus the following dialog box will be displayed:

File Save Interface

Hotlid=off 2007-11-1 10:05:00

abc

User: BOCEO

File Name: R1

Password: ****

Password Check: ****

Select Sample Volume:
050 μ l

The user can input Sample Volume (Unit: Micro liter) by the same way as that of the main interface. Press “**Back**” to go back to File List Interface; Press “**Run**” to enter into the file running interface.

Note: Setting the password as 0~9 number character.

When the file is normally running, “**•••**” at “Now Running” will continuously flash. When running is over, the system will remind “File run over”

- ✧ Press “**Stop**” and it will remind “Confirm stop running?”. According to the reminding information to select “STOP” or “START”. If the user make no choice, the system will continue to run within 100 seconds automatically.
- ✧ Press “**Pause**” and it will remind “Now pause running”. According to the

File Running Interface

Hotlid=off 2007-11-1 10:05:00

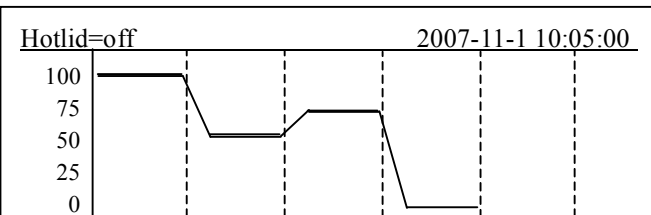

Temp	1c 95.0	2c 55.0	3c 72.0	4 04.0		
Time	01:00	02:00	01:45	00:00		

File Name: PCR1
 User: BOECO Now Running **•••**
 1c Time=00:00 Cycle1 01 of 10

1	2	3	4	5	6	7	8	9	10	11	12
95.0	95.1	95.2	95.4	95.7	95.9	96.1	96.4	96.6	96.8	96.9	97.0

Total Time: 00h 56m Remaining Time: 00h 56m

reminding information you can select “START” to continue. If you don’t make a decision within 100 seconds, the system will continue running automatically.

- ✧ Press “**View File**” to view edited PCR programs.
- ✧ Press “**Skip**” to stop current temperature and run the next.
- ✧ Press “**Enter**” key checking the grads temperature value.

4.2 How to set system parameters

In the main interface, press “**System**” to enter system parameter setting interface

Press “**Enter**” to move the cursor to next item. The option is followed by the symbol “**↕**”. Press “**Up/Down**” to roll the option for selecting, and other information can be entered information by pressing “**Digit & Letter**”. Press “**Right/Left**” to move the cursor’s position.

- ✧ Press “**Back**” to go back to the main interface.
- ✧ Press “**Save**” to save the parameters.

System Parameter Setting Interface

Hotlid=off	2007-11-1
10:05:00	
Date:	03-10-22
Time:	14:53:19
Default User:	BOECO
Default File:	PCR1
Control Mode:	Block
Hotlid:	off
Key Sound:	Yes
Run End Sound:	Yes

Special Reminding: When set the parameter, please press the “Save”, otherwise the parameter remains the original one.

NOTE: After set the parameter, please press “Save” to confirm setting, otherwise the parameter remains the original one.
 Before the instrument leaves the factory, its inside clock has been adjusted in accordance with Beijing Time.
 For the first use of the instrument, you are advised to confirm whether the date and clock time are set right as local time.

4.3 Characteristics of Temperature Distributing of Gradient Block

The gradient block adopts 3-group temperature control units, so that the gradient temperature appears curve distribution as showed in the following figure (Setting temp is 40℃, and gradient setting temp is 20□). The gradient distribution among every block’s hole temperature is not even; the temperature difference in mid of block is larger than that of its outer. Therefore, please refer to the temperature displayed on the machine for every hole’s temperature when operating gradient block.

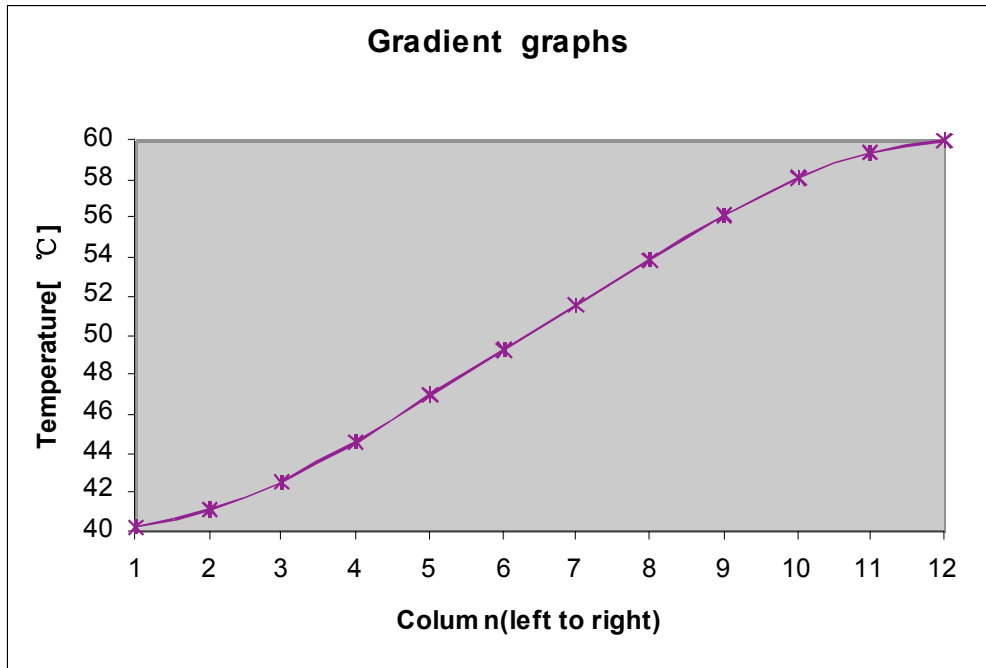

5 How to Input and Output the PCR Program

5.1 Connect Usb Flash Memory

Press “usblink” key in the main interface to enter the usb usblink interface. If insert usb flash memory, display as the left fig.

- ✧ Press “**Back**” to go back to the main interface.
- ✧ Press “**Input**” key to choice input file from usb flash memory, the equipment display usb user list.
- ✧ Press “**output**” key to choice export file to usb flash memory, the equipment display the local file user list.

Usb Link Interface

Hotlid=off	2007-11-1 10:05:00			
<p>The Insturment has Connected UsbDisk. Please Choose Input or Output File.</p> <p>Press F1 to Back Press F4 to Input File Press F5 to Output File..</p>				
<input type="button" value="Back"/>	<input type="button" value=" "/>	<input type="button" value=" "/>	<input type="button" value="Input"/>	<input type="button" value="Output"/>

Usb Link Error Interface

If no inserted usb flash memory, display as the left fig. Press “Back” key can return back to the main interface.

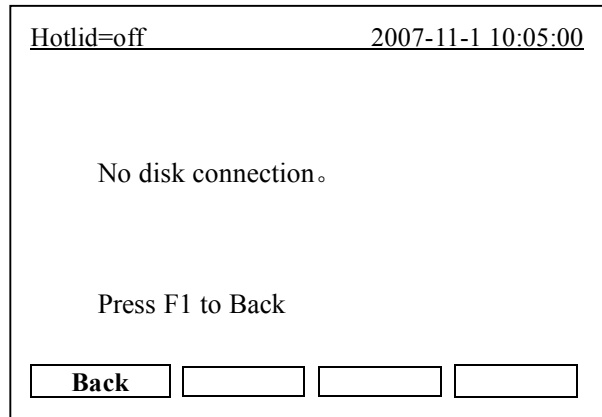

5.2 Input file from usb flash memory

- ✧ Press “Back” key can return back to the usb link flash memory interface.
- ✧ Press cursor up/down moving key to choice the copy file user.
- ✧ If the user number bigger than 30, press cursor left/right key to previous/next page.
- ✧ Press “view” key to display usb file list.

Usb User List

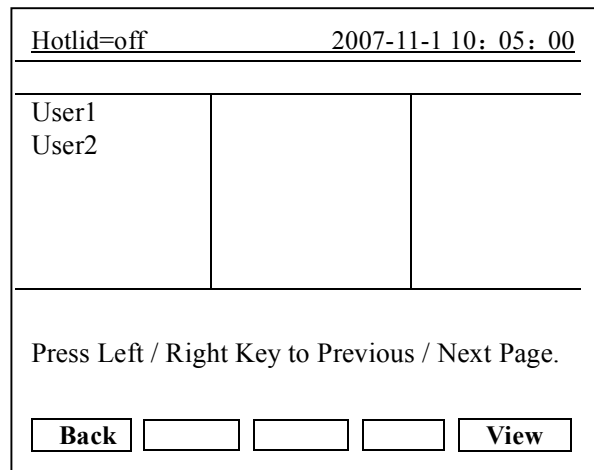

Press “Back” key can return back to usb flash memory user list interface.

- ✧ Press cursor up/down moving key to choice the copy file
- ✧ If the file number bigger than 30, press cursor left/right key to previous/next page.
- ✧ Press “copy” key to input file.
- ✧ If copy correct, display the following dialog box.

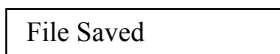

otherwise display:

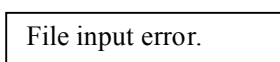

Usb File List

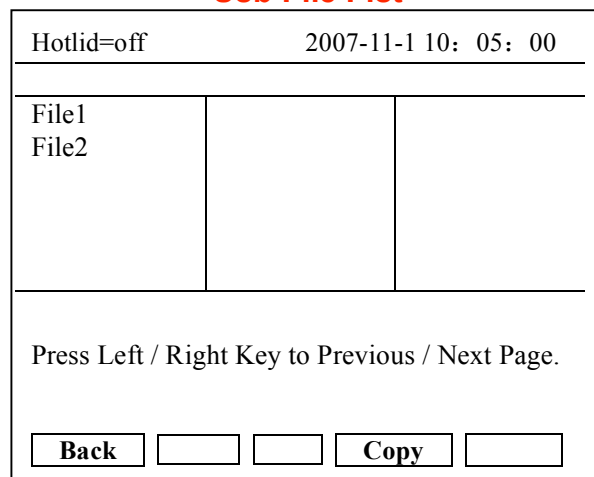

5.3 Export file to usb flash memory

- ✧ Press “Back” key to return back the usb link flash memory interface.
- ✧ Press cursor up/down moving key to choice the copay file user.
- ✧ If the user number bigger than 30, press cursor left/right key to previous/next page.
- ✧ Press “view” key to display usb file list.

Equipment User List

Hotlid=off		2007-11-1 10: 05: 00	
Local			
User1			
User2			
Press Left / Right Key to Previous / Next Page.			
Back	[]	[]	View

- ✧ Press “Back” key can return back to equipment user list interface.
- ✧ Press cursor up/down moving key to choice the copay file.
- ✧ If the file number bigger than 30, press cursor left/right key to previous/next page.
- ✧ If copy correct, display the following dialog box.
- ✧ Press “view” key to display usb file list.

Equipment File List

Hotlid=off		2007-11-1 10: 05: 00	
Local			
File1			
File2			
Press Left / Right Key to Previous / Next Page.			
Back	[]	Copy	[]

File Saved

Otherwise display

File output error.

Note: Usb read-write user number is 500, every user's file number is 2000.
Usb read-write fixup list ,usb root list descended BOECO folder.
Every user is one son folder of BOECO folder.
Forbid to insert and pull out usb flash memory very fast. To protect apparatus and usb flash memory, if insert and pull out usb flash memory, the apparatus will close usb function until the next boot-strap.
The operation method for double module is the same, the link of usb flash memory is only for two module under the original interface.

Chapter Five Connection of Computer

1. Software installation

Click "Setup.exe" to Installation TC-PRO Program.

2. Online setup

TC-PRO has configurable embedded internal networking modules, provide the corresponding tools set.

3. Software installation

The first step:click to run need_setup.exe.

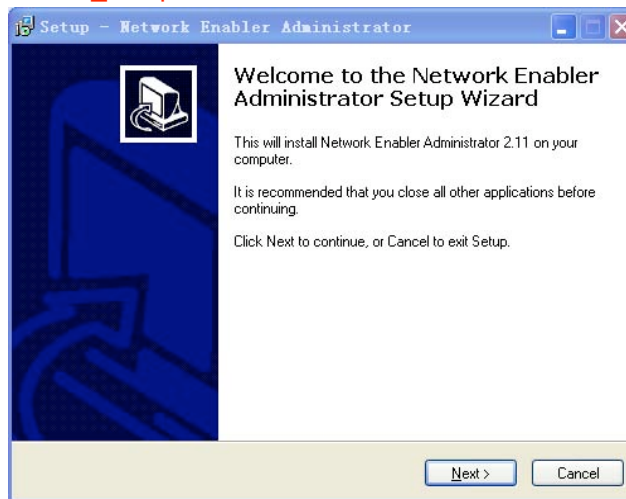

The second step: click next button.

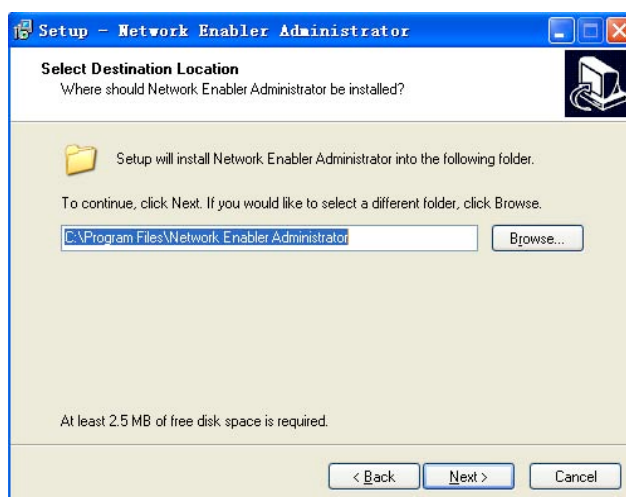

The third step: choice installtion list, click next button.

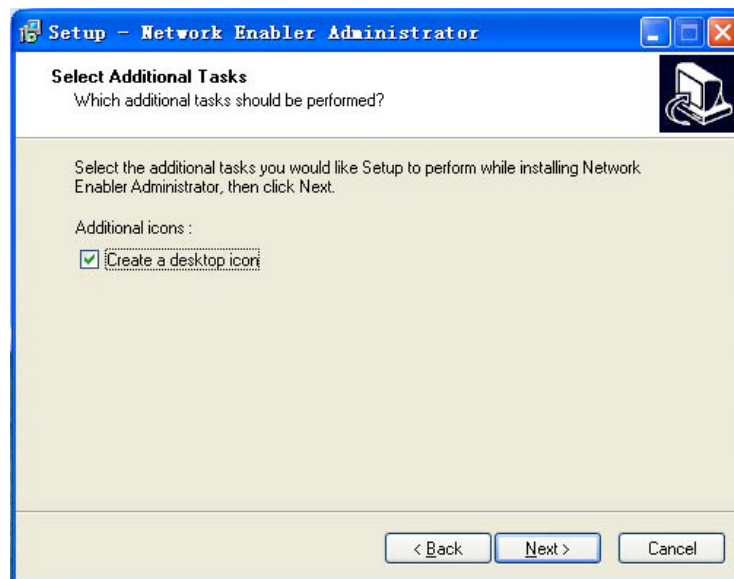

The fourth step: click next button.

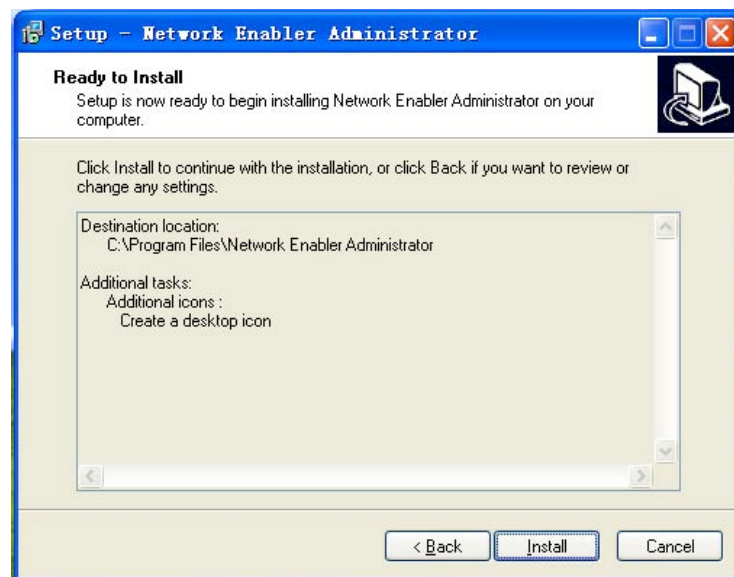

The fifth click install button.

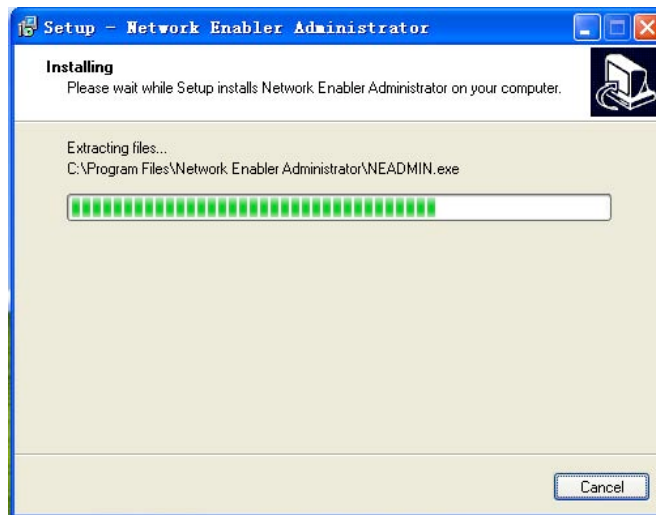

The sixth step: installation finished, click finish button.



4. Configure your equipment

4.1 Network Connection

Link the equipment and computer lines through the network connection (Cross, Class B

Connection)

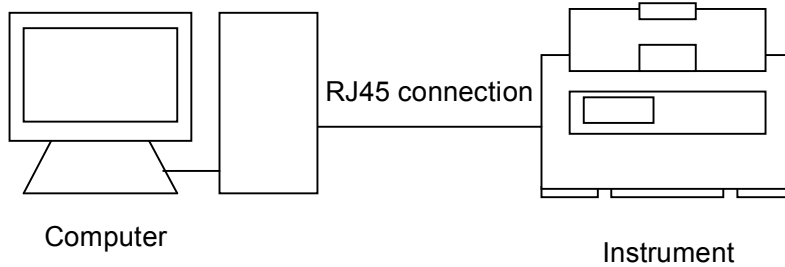

4.2 Network Enable Administrator

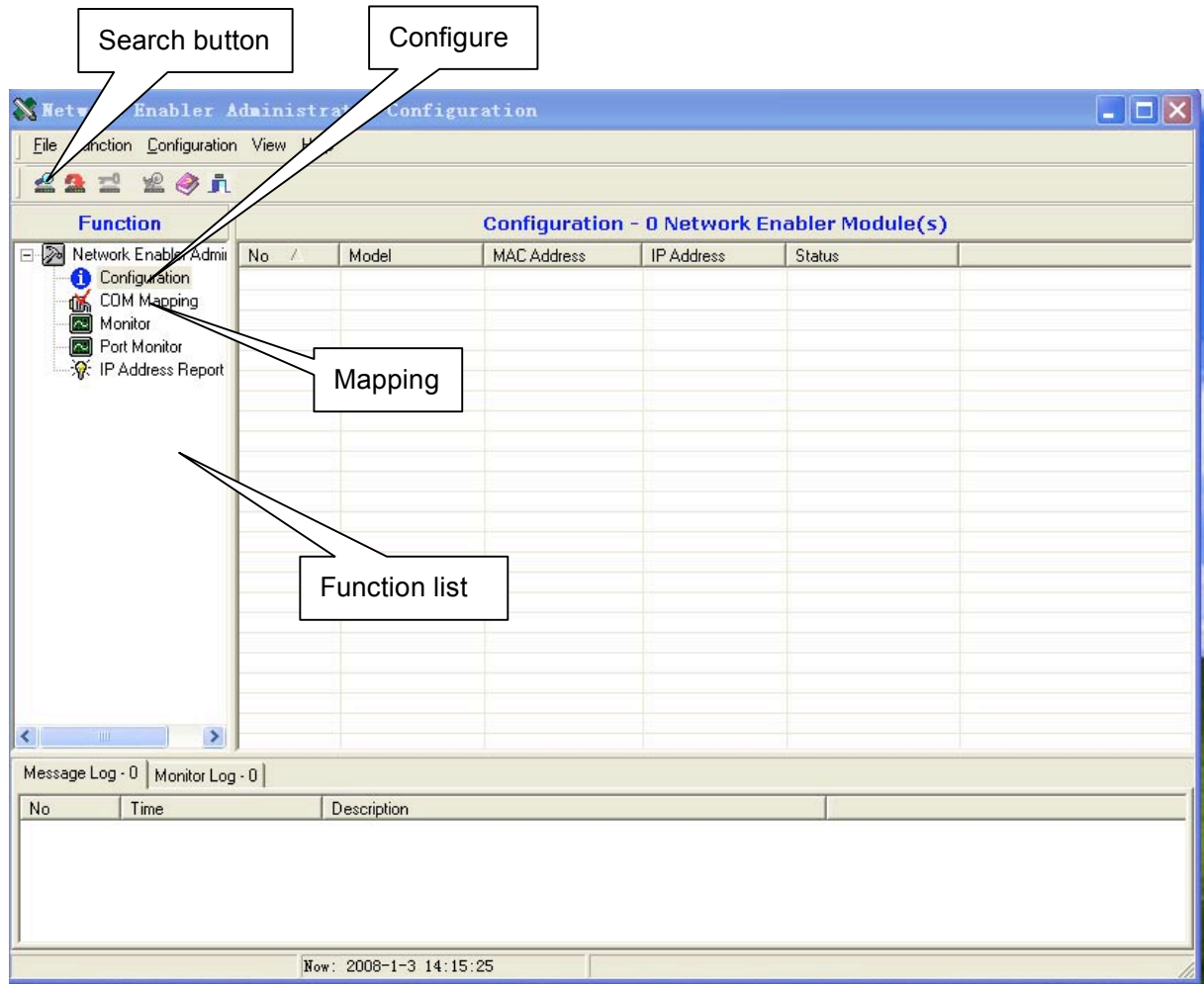

4.3 Configure

Click the Search button, the device will search tool automatically.

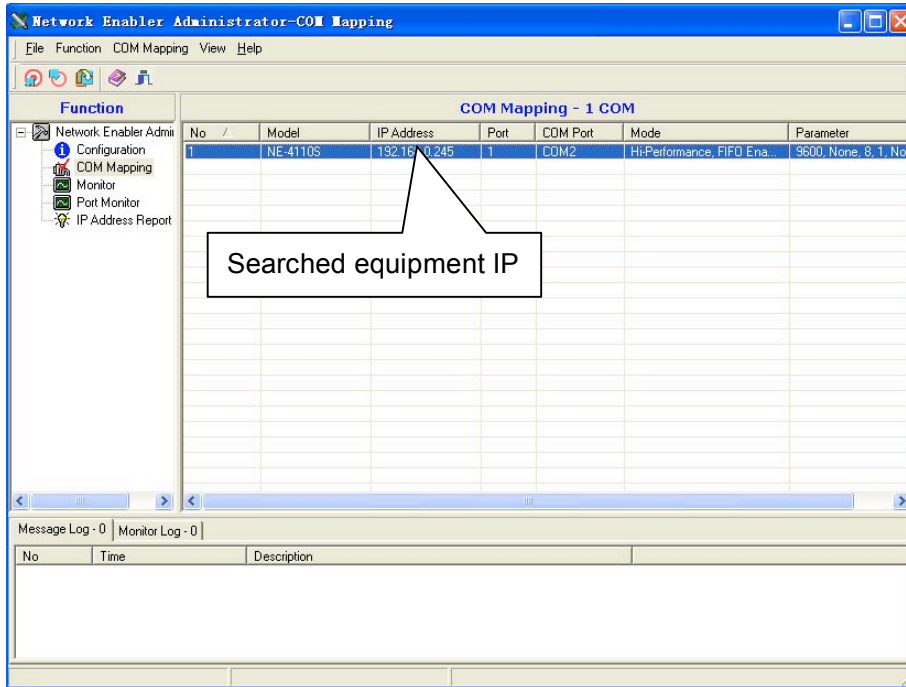

Double-click the searched IP on the column, open the attribute page and choice the network option.

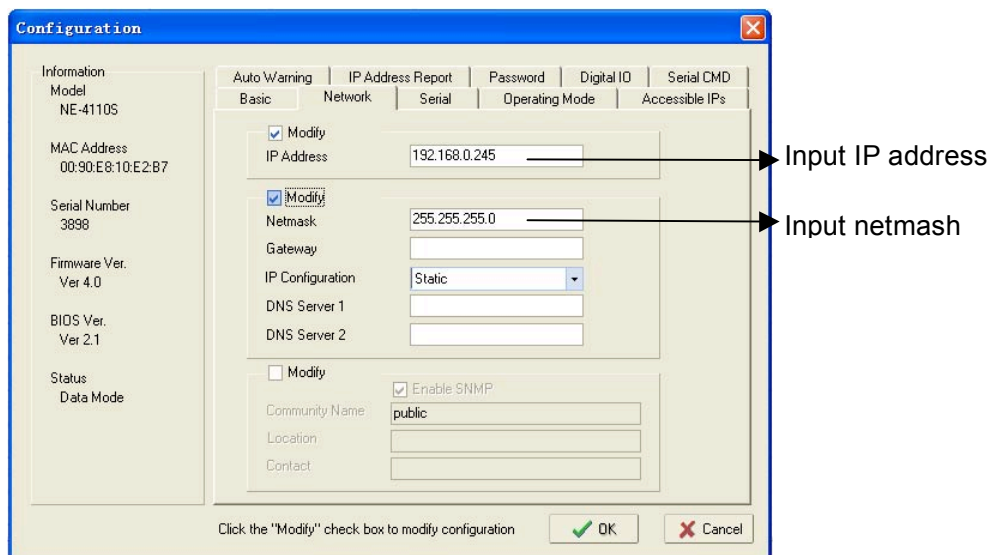

Open the attribute page and choice operating mode option then click setting button.

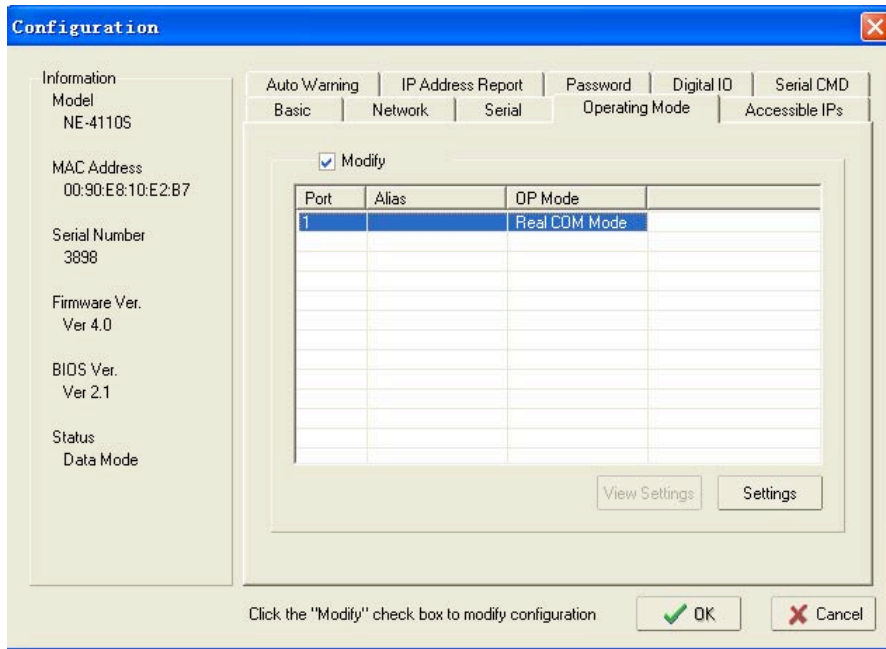

The operating mode choice TCP server mode.

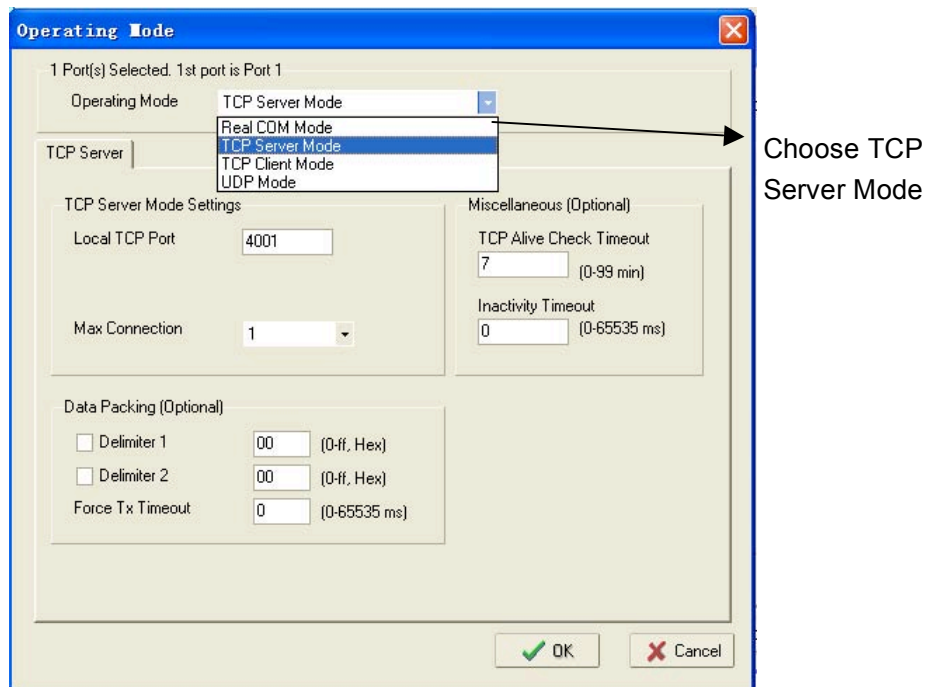

Single click ok button, finish IP address setting.

Single click function list" COM MAPPING".

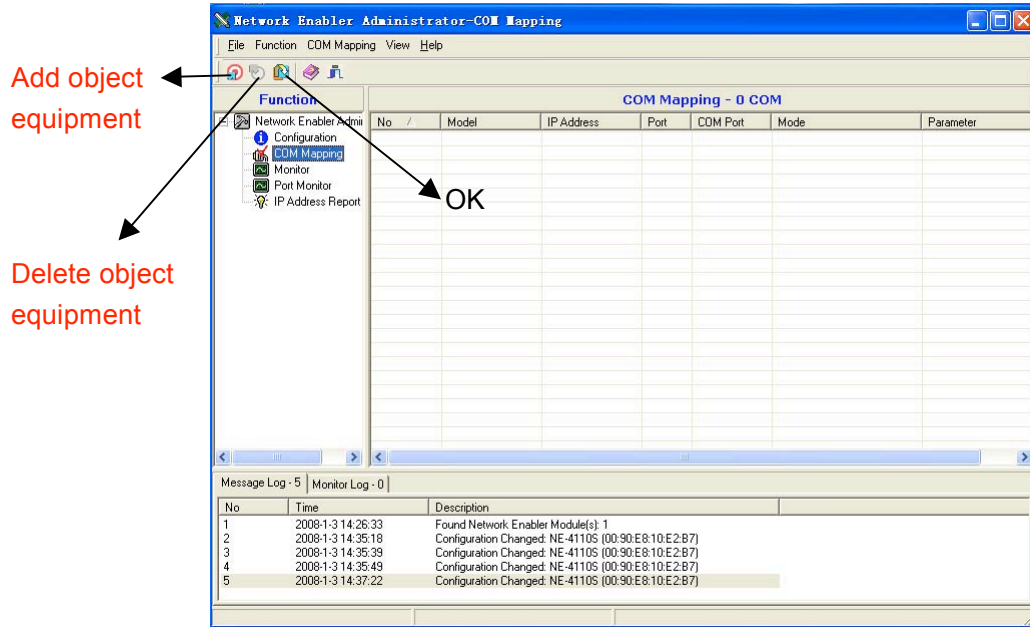

Click "add object equipment" button.

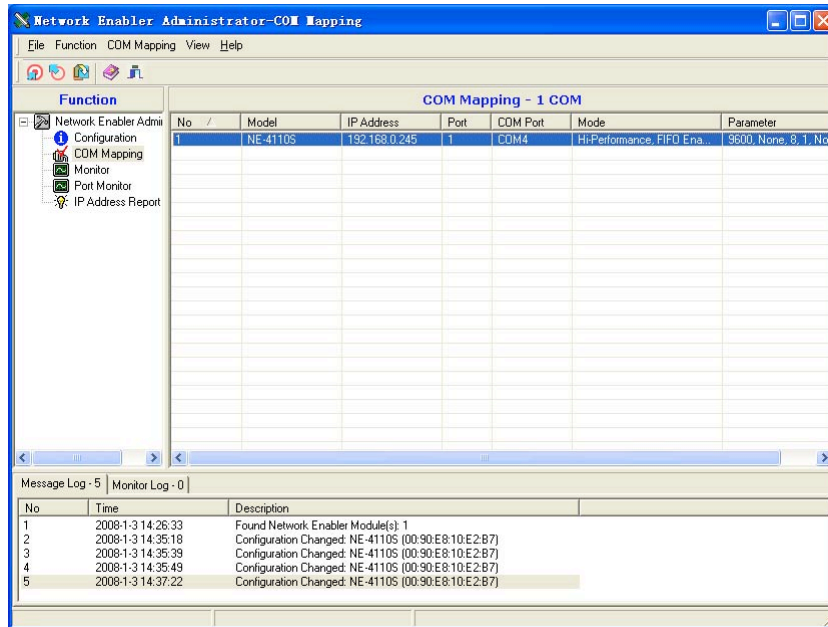

Double-click on the column searched IP, setting the mapping attributes page, select Advanced Settings, setup as the following fig.

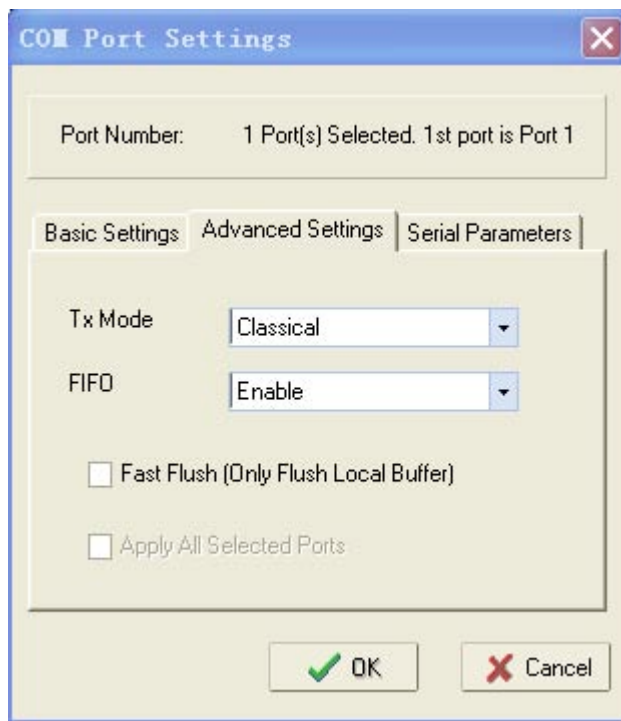

Choice Serial Parameters, setup as the following fig.

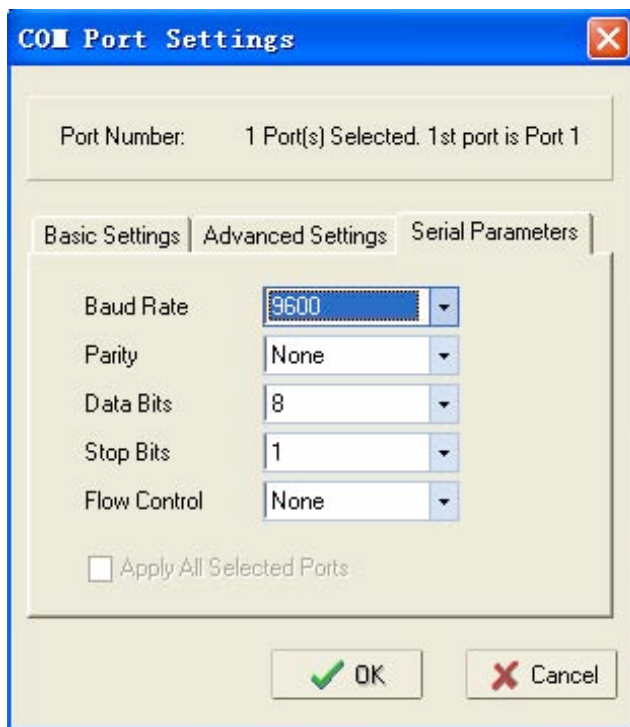

Click ok button, and click OK button of the application settings, and click the Remove equipment, completed mapping settings.

- Note:**
- 1 The IP address is not unanimous when multiple devices interconnection.
 - 2 In the first use, re-equipped the equipment.
 - 3 Need to set up the same subnet when multiple equipment networking.
 - 4 Device does not support automatic ip address functions.
 - 5 Multiple equipment networking can use switches, such as the use of cross-HUB requires the use of network connectivity.

5.Main interface

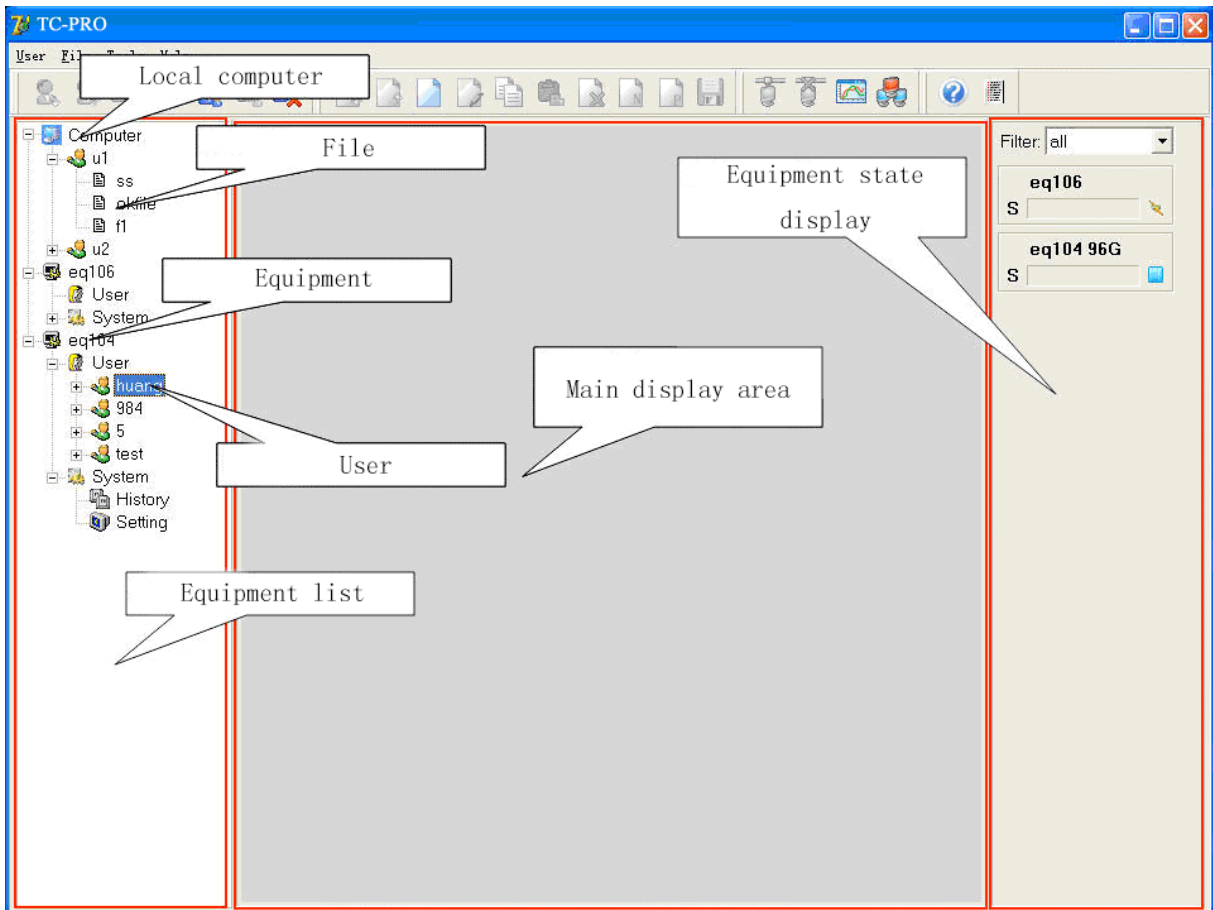

6. Toolbar

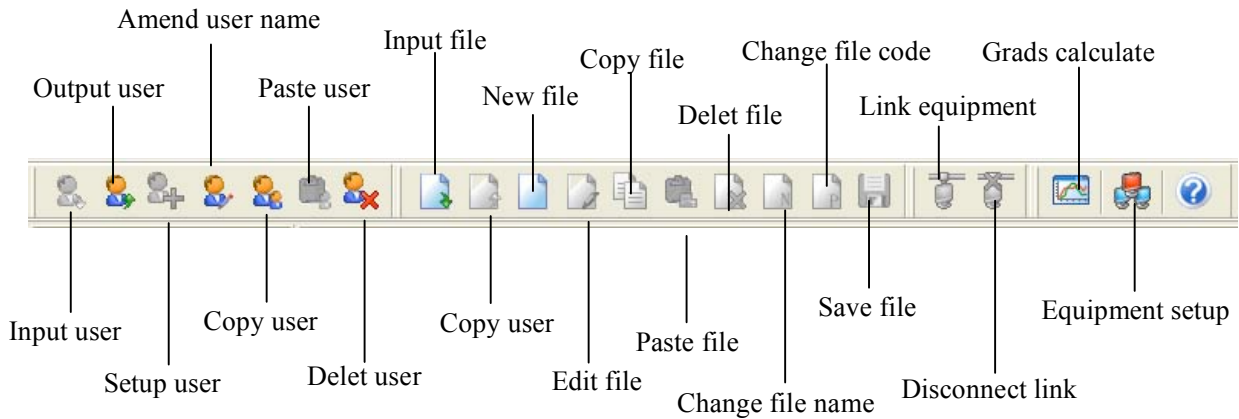

7. Basic manipulation

Run a file

1. Open the file of the equipment or the machine.
2. Click Run button.
3. Select test-tube type and size of the test tube.
4. Click ok button operation.

Clew:

If the file is saved in the computer, pre-operational options related equipment operation.

Checking the operating file

1. Document if the equipment running, the device will be displayed from the bottom Run File (A / B) Options
2. Double-click Run File (A/B), display the operation file content and equipment running states.

Clew:

By clicking Pause / Stop button to pause / equipment running.

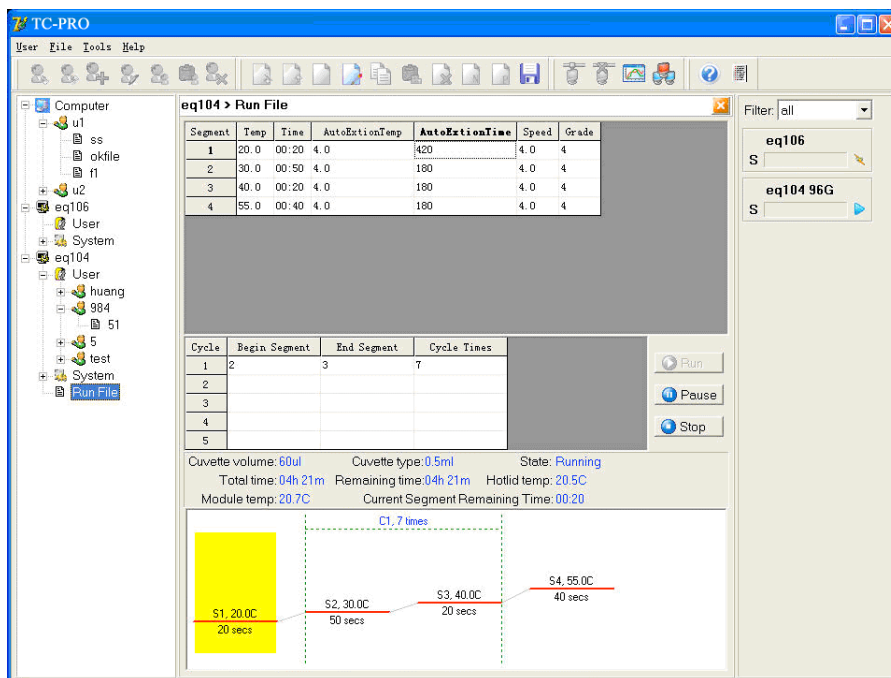

Check history information

Double-click the historical option in the System option to show the historical information.

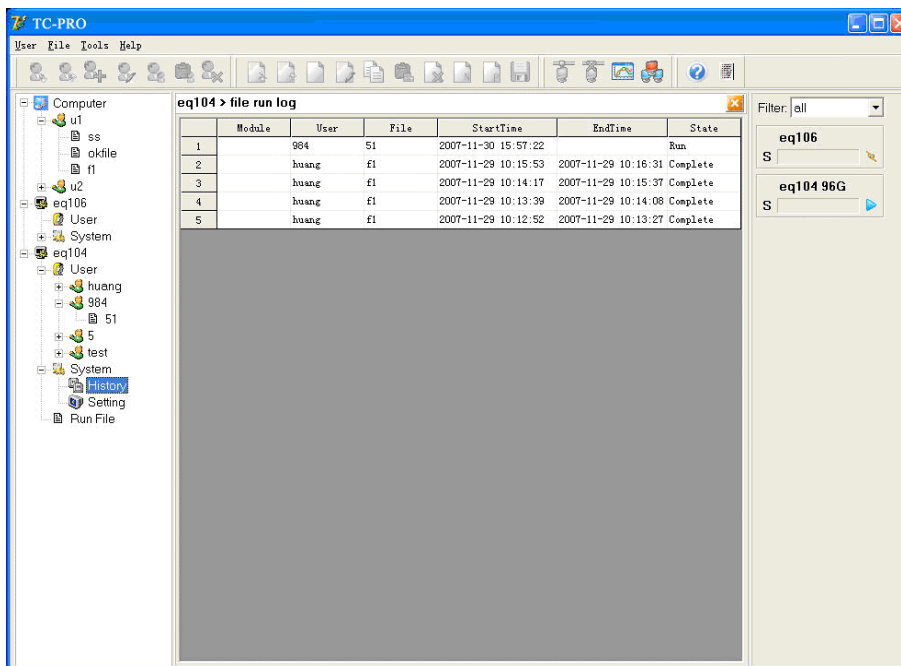

Checking the equipment storage state

Double-click the System to view equipment storage condition.

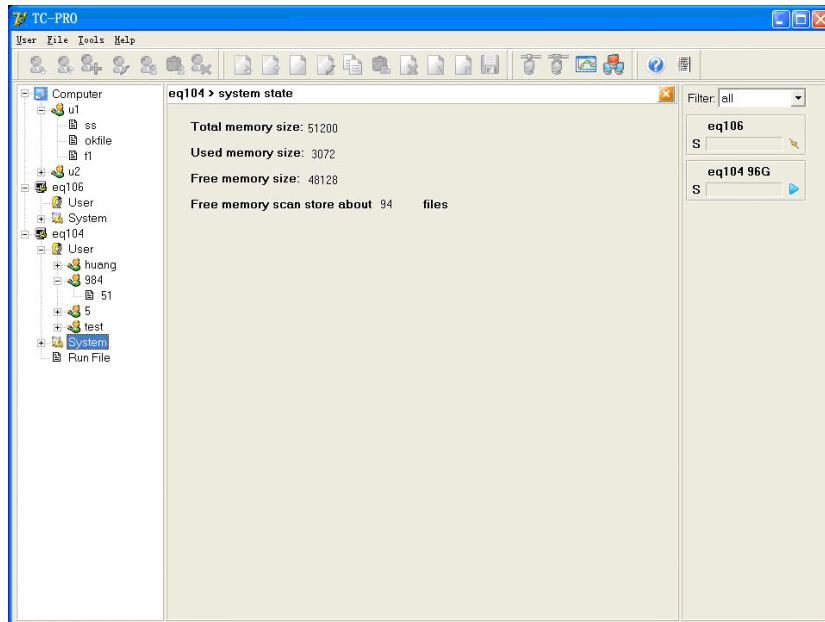





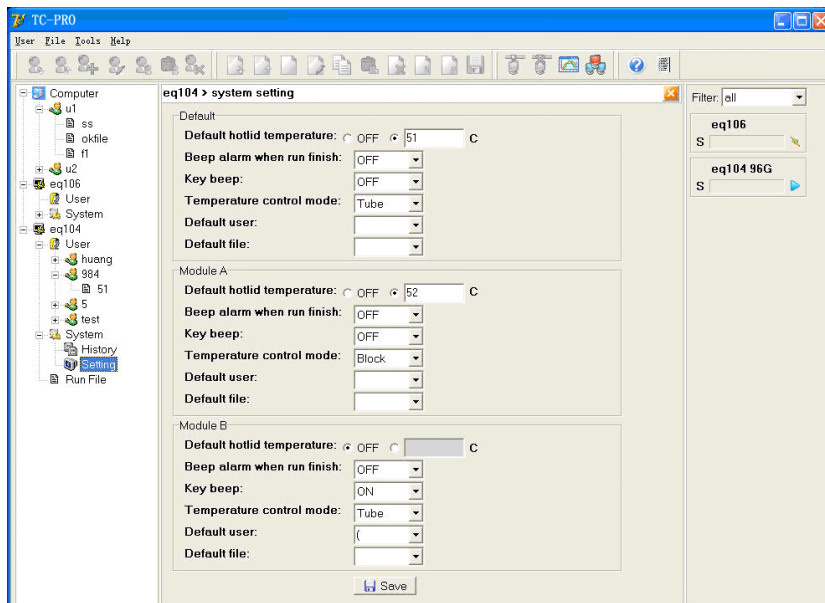

Setup the system parameter

Double-click the setting option of the System options to set-up system parameters.



8. User manual

How..

-  **Create new users**
-  **Change the user name**
-  **Copy user**
-  **Paste user**
-  **Delete user**
-  **Input user**
-  **Export user**

Create a new user

1. Choose the name of the equipment list or any user name.
2. Choice the create user menu in “User” menu, pop-up user dialog box.
3. Enter your user name, click ok button.



Change the user name

1. Choice change the user name option.
2. Choice the “Change User Name” menu under the User menu, pop-up the “Change User Name” dialog box.
3. Import user name, click the ok button.

Clew:

User can't change the user name when the file of this user is opening.

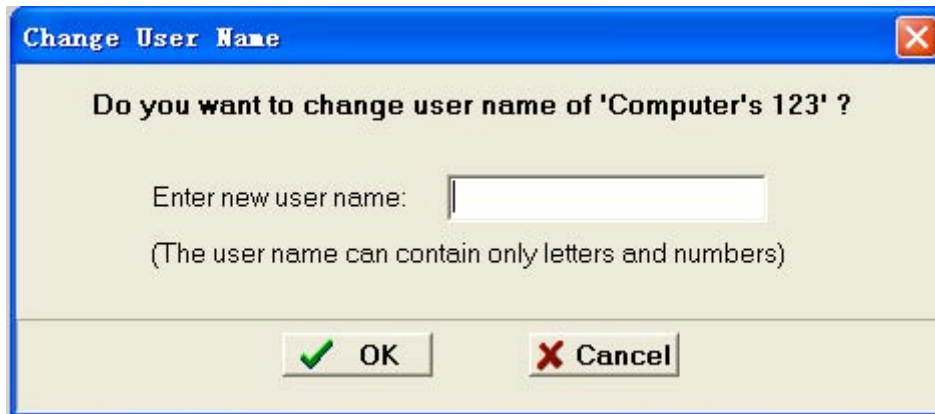
**Copy user**

1. Choice the user name needed to copy.
2. Choice the “Copy User” menu under User menu.

Paste user

1. Choose the name of the equipment list or any user name.
2. Choice the “Paste User” menu under “User” menu.

Clew:

1. If the copy user already occurs, and the file is opening, can't been plaster user.
2. Only can plaster between the local computer and equipment.

Delete user

1. Choice the user need to be deleted.
2. Choice the “delete User” menu under “User” menu.

Clew:

Can't delete user when the file open.

Input user

1. Choice the local computer.
2. Choice the Import User menu under the User menu.
3. Choice the input list, click the open button.

Clew:

Can't input user if the existent user is opening.

Output user





1. Choice the user which want to export in the local computer.
2. Choice “Export User” menu under “User” menu.
3. Choice the export list, click ok button.

Clew:

Can't export user when the file open

9. File menu

How...

-  **Create new file**
-  **Open and edit file**
-  **Copy file**
-  **Paste file**

- ? Delete file
- ? **Change file name**
- ? **Change the file password**
- ? **Save file**
- ? **Input file**
- ? **Export file**

Create new file

1. Choice the user which need to found new file.
2. Choice the “Create New File” menu under File menu, pop-up the dialog box.
3. Input the file name and password, click ok button.

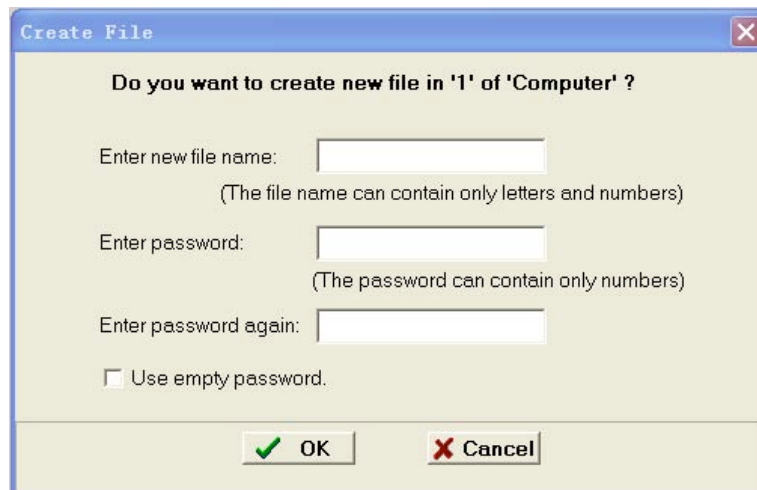

Edit file

1. Double click the equipment list user option, open the file list and double click edit file or create new file.
2. Edit the file content, click “Save” button to save the file.

Clew:

May examine the whole steps under the figure.

When user edit the file, if the file has password, user must input the password then edit the file.

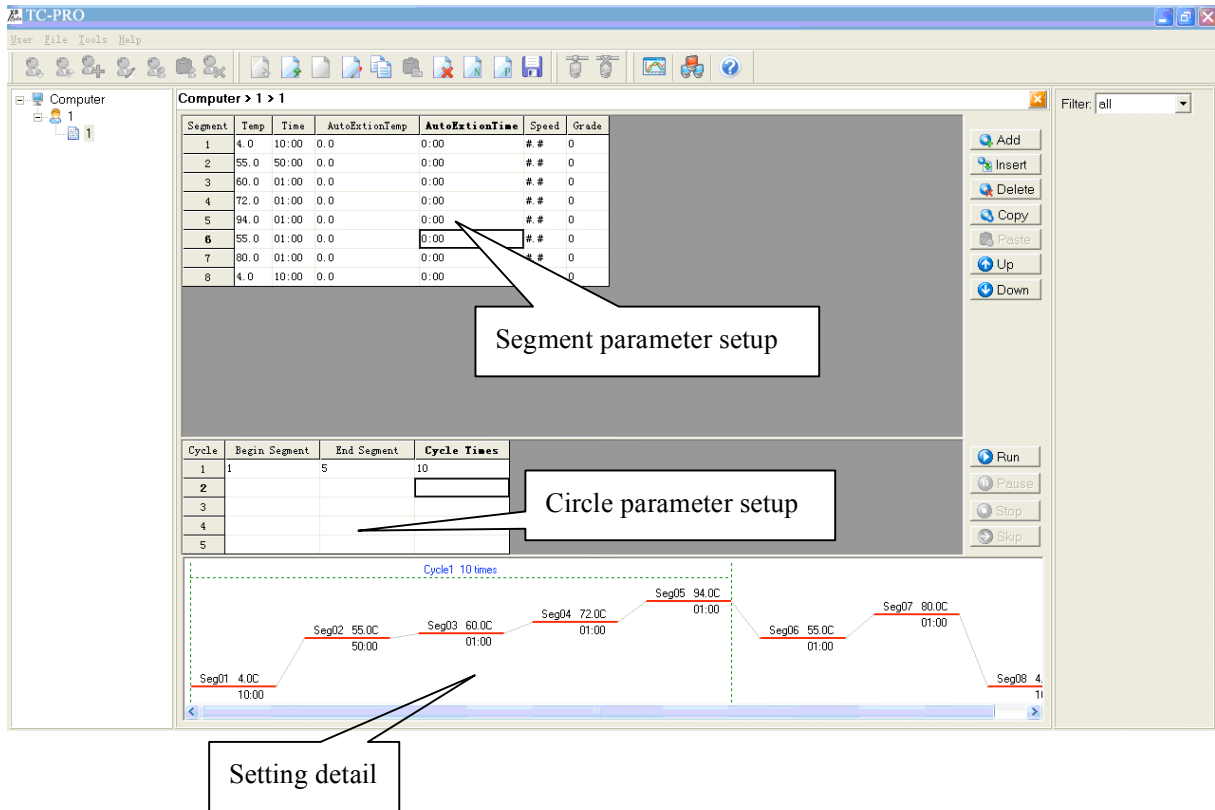

Copy file

1. Choice the file needed to copy.
2. Choice the “Copy File” menu under File menu.

Paste File

1. Choose the user option under the equipment list.
2. Choice the “Paste File” menu under “File ” menu.

Clew:

Only can paste file between computer and equipment.
 Can't cover the opened existent file.

Delete File

1. Choice the file need to delete.
2. Choice the “Delete File” menu under the File menu

Clew:

Can't delete the opened file.

Change the file name

1. Choice the file which user want to change the name.
2. Choice the “Change File Name” menu under File menu.
3. Input file name, click OK button.

Clew:

Can't change the opened file name.

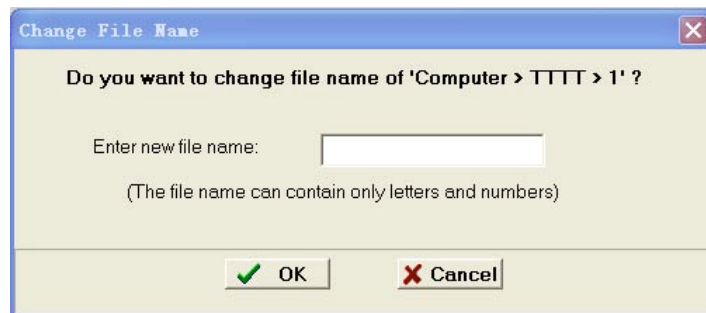
**Change the file password**

1. Choice the file which want to change the password.
2. Choice the “Change File Password” menu under “File” menu, pop-up dialog box.
3. Input the old password, the new password and click OK button.

Clew:

Can't change the opened file name.



Save file

Click "Save File" option to save the file after modification.

Input file

1. Choice the local computer user option.
2. Choice "Export File" menu under the File menu.
3. Choice the file, click open button.

Clew:

Can't input the opened file.

Export File





1. Choice the file need to export.
2. Choice the "Export File" men under "File" menu.
3. Choice the export outlet, click OK button.

Clew:

Can't export the opened file.

10. Tool menu

How...

-  **Connect equipment**
-  **Disconnection**
-  **Grads calculate**
-  **Change equipment ip and name**

Connect equipment

Choice the equipment, click "Connect" menu.

Clew:

One equipment can only connect one computer at the same time.

Disconnection

Choice the equipment, click the "Disconnect" menu.

Grads Menu

1. Choice the grads menu.
2. Import the grads origination point, and the grads value.
3. Choice the computer module type 8x12 (96well) 16x24 (384well) .
4. Click Calc. Button.

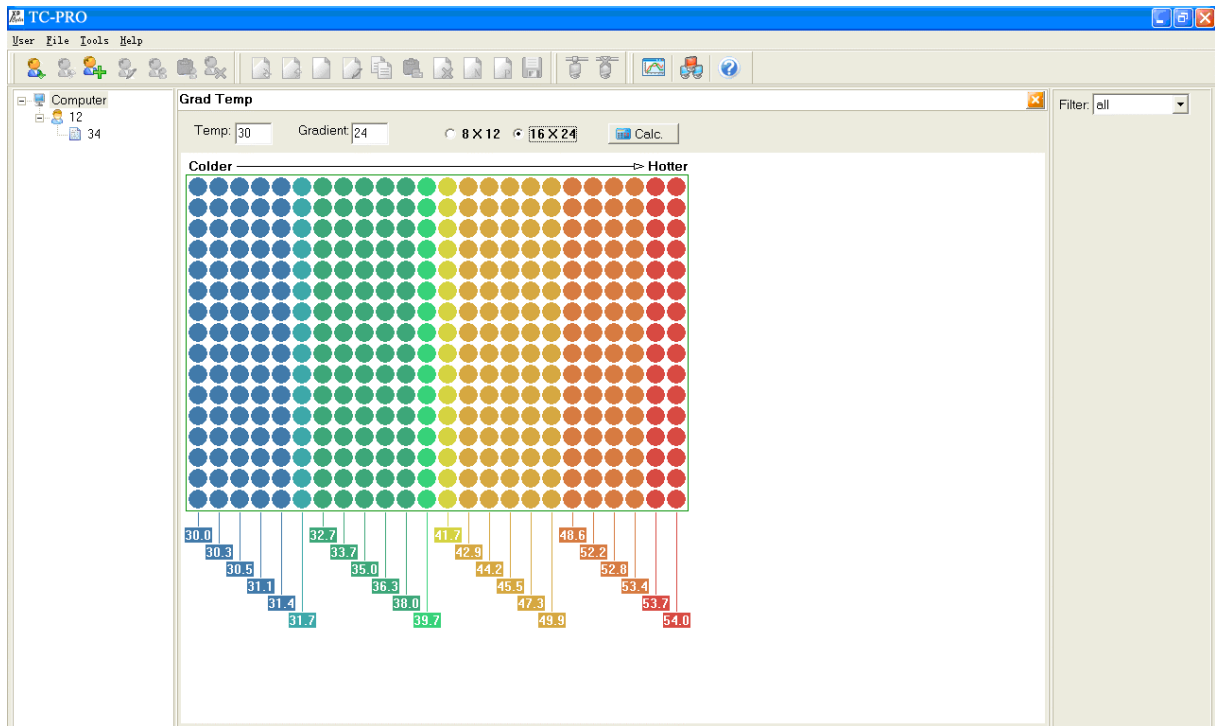
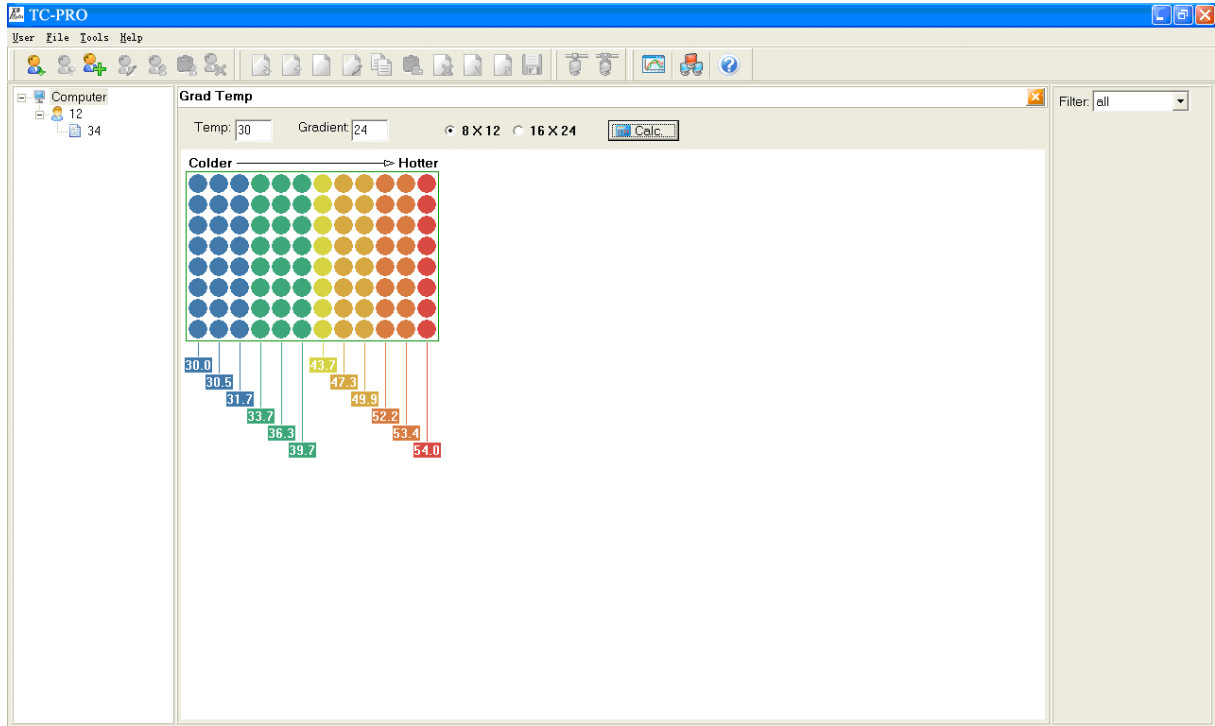

Change the equipment IP and the name

1. Choice the “Server Setting” option under “tool” menu, pop-up the setting dialog box.
2. Click the “Add” button to add a row.
3. Click the “Delete” button to delete the current row.
4. Put the ip address and alias, click “Save” button to save the setup.

Clew

1. The setup will go into effect until the software restart.
2. Ip setup should be corresponding to the equipment.

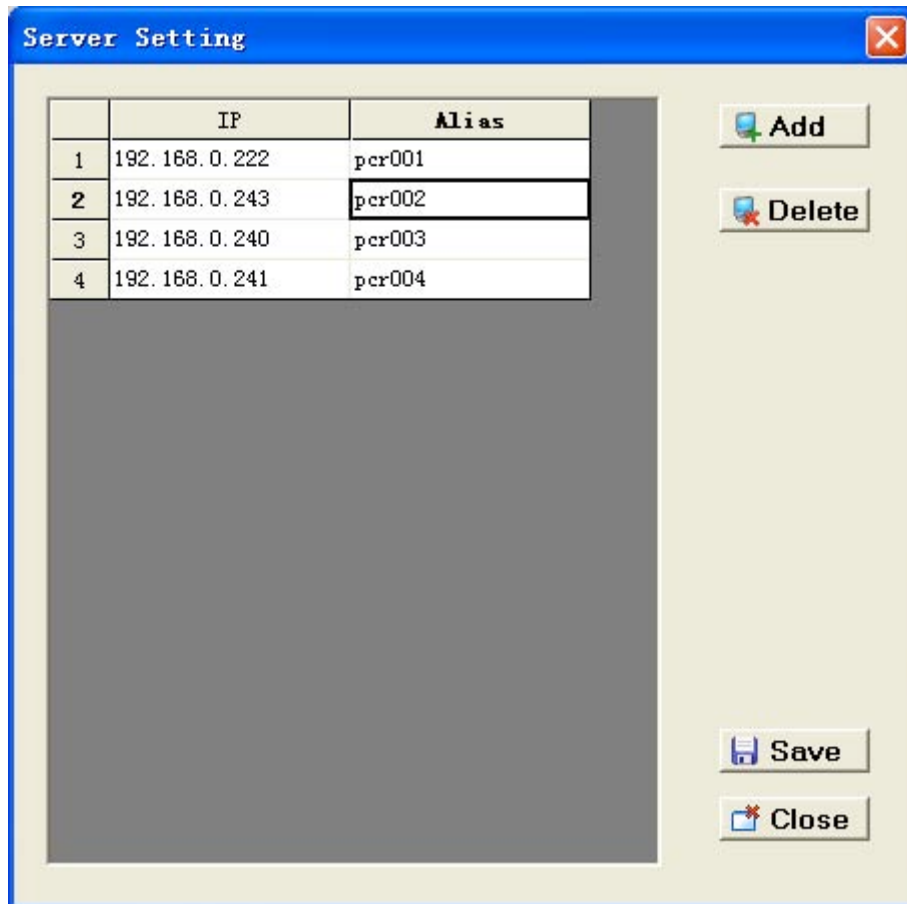

Chapter Six Firmware Upgrade

1. Configure your equipment

Connect the equipment and computer lines through the network (cross, then Class B).

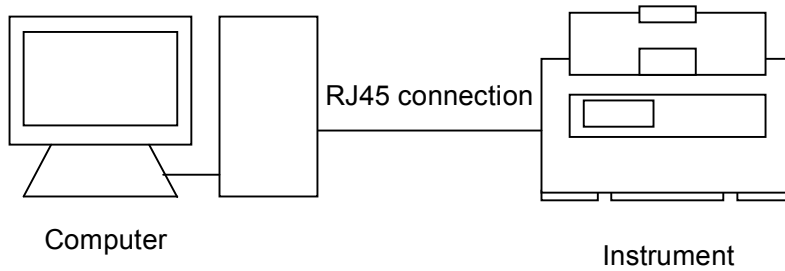

2. How to Upgrade the Software

- 1) Open apparatus power to start instrument, hold down the F1 key at the same time, then equipment enter the software upgrade readiness estate, the apparatus display “Prepare to upgrade . . .”.
- 2) Operate the procedure Network Enable Administrator. Equipment will use virtual equipment mapping for communications during upgrades.

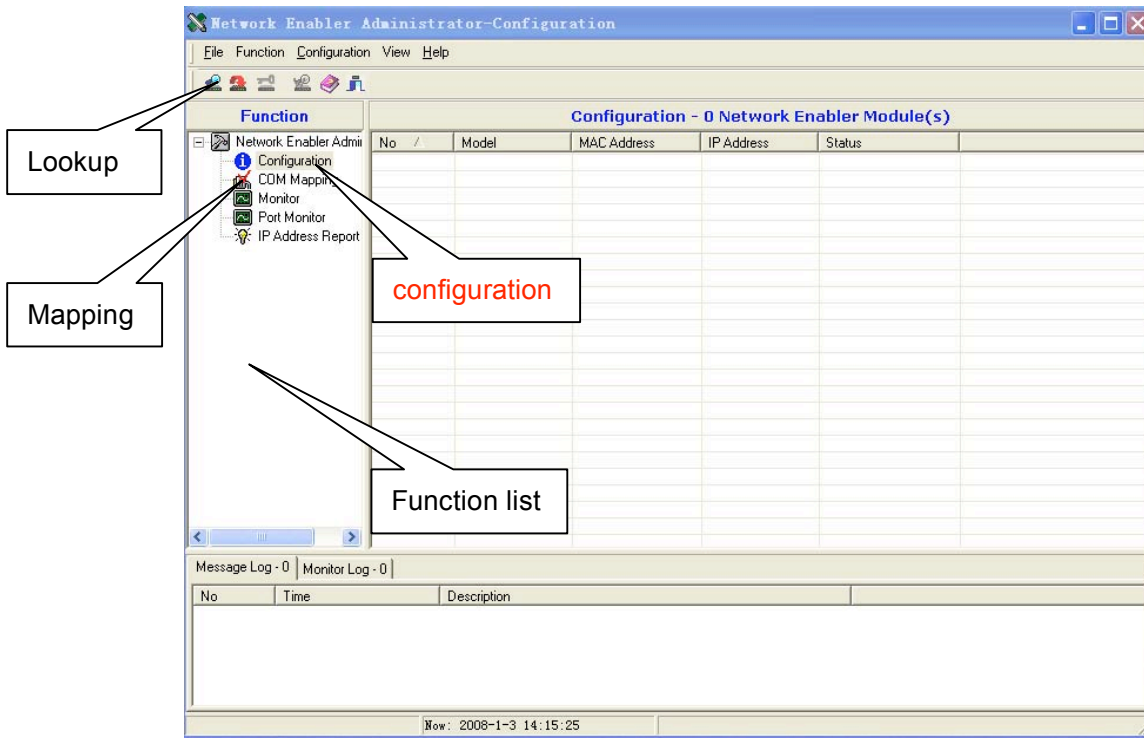

3) Configuration

Click the Search button, the device will search tool automatically.

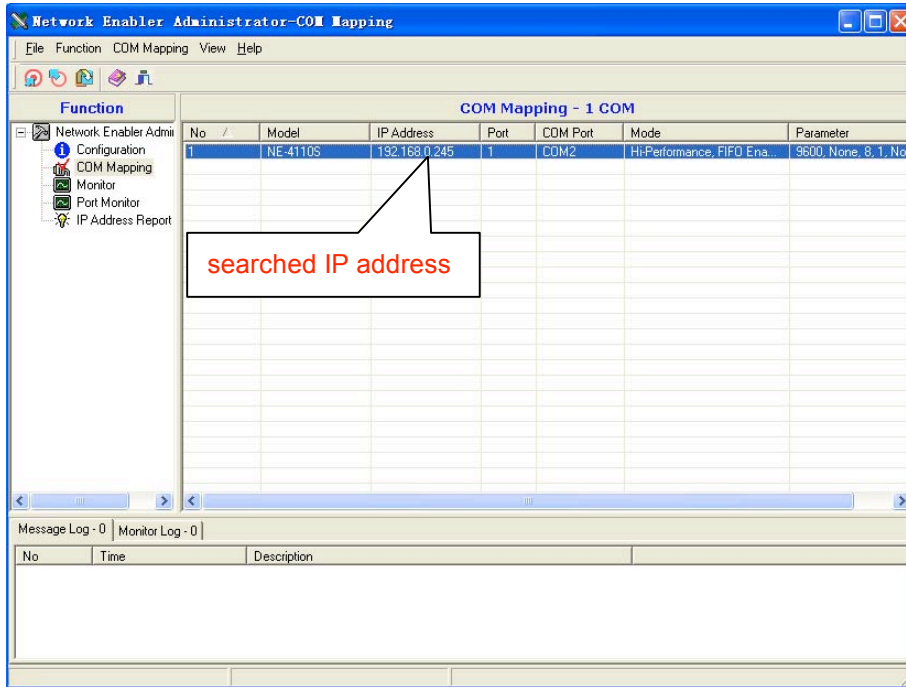

Double click the searched IP address, open the property page to choice the network option.

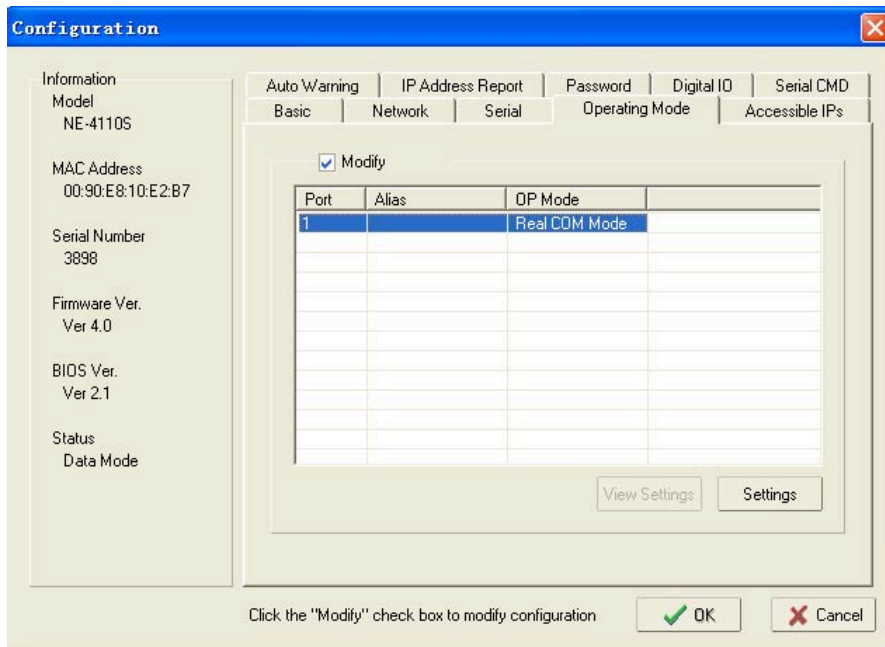

Open Operating Modemenu, click settings, open the property page to choice operating mode and click setting button.

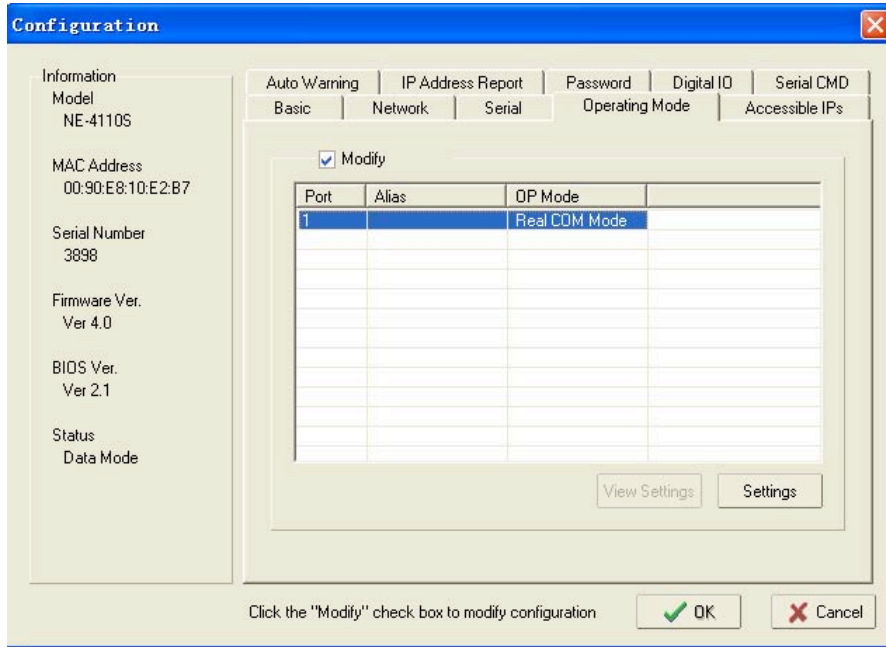

Choice "Real Com Mode" in operation Mode.

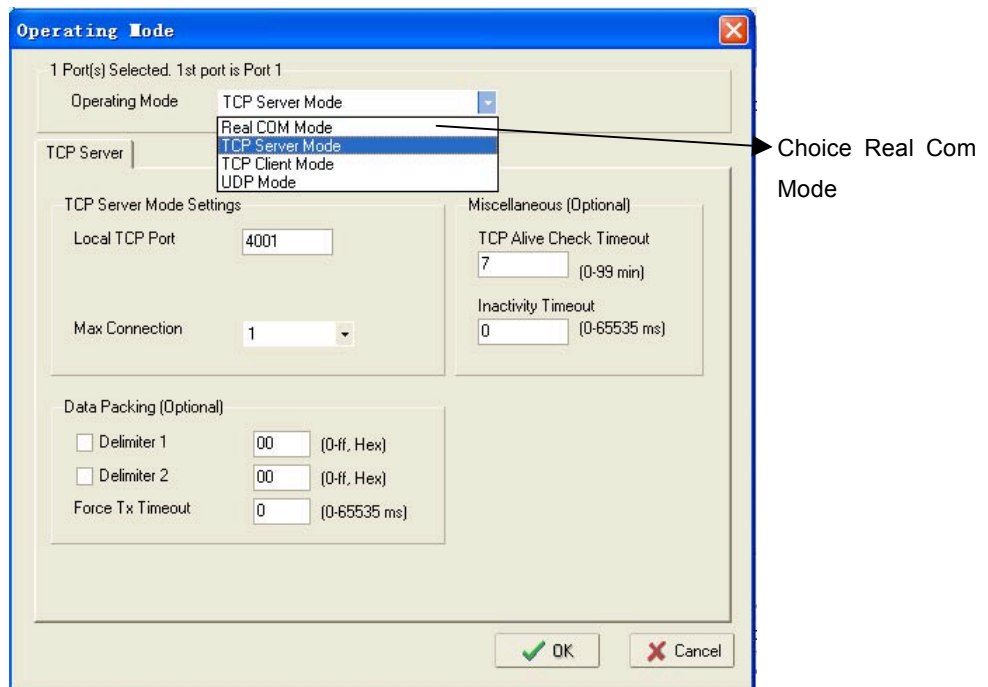

Click the function list "COM MAPPING" option.

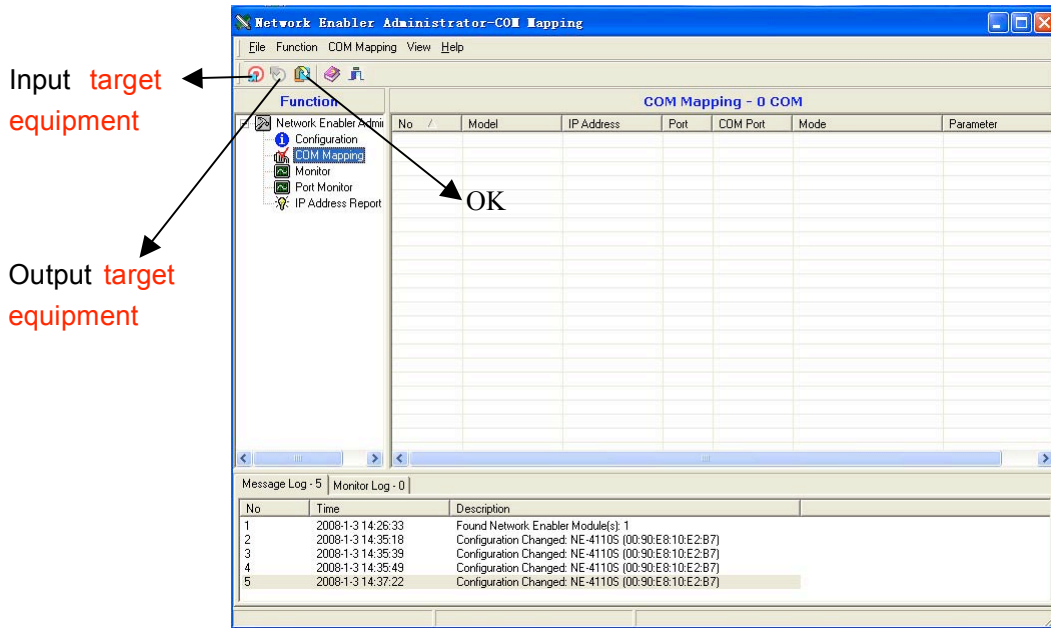

Click to add target equipment button.

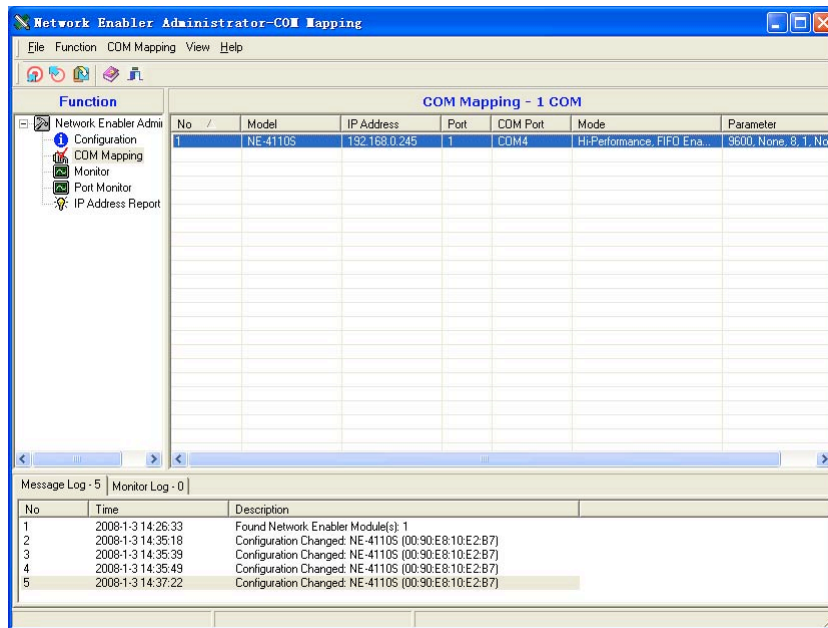

Double click the searched IP address to set the mapping property page, choice “Advanced Setting”, as below:

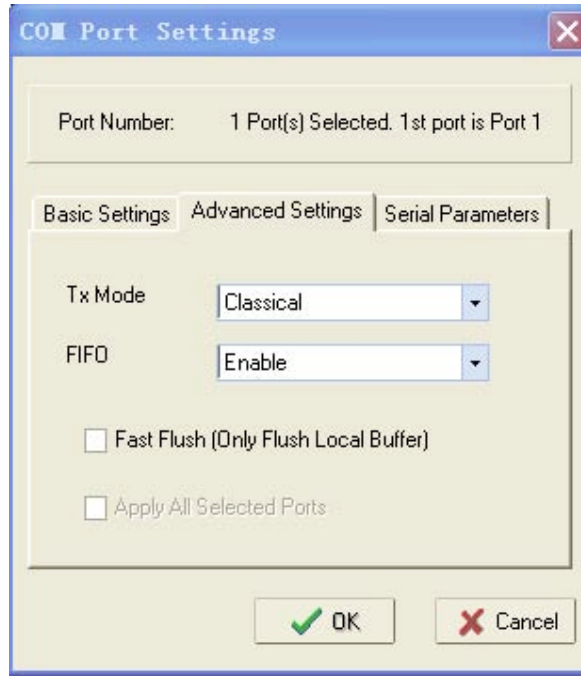

Choice “Serial Parameters”, as below:

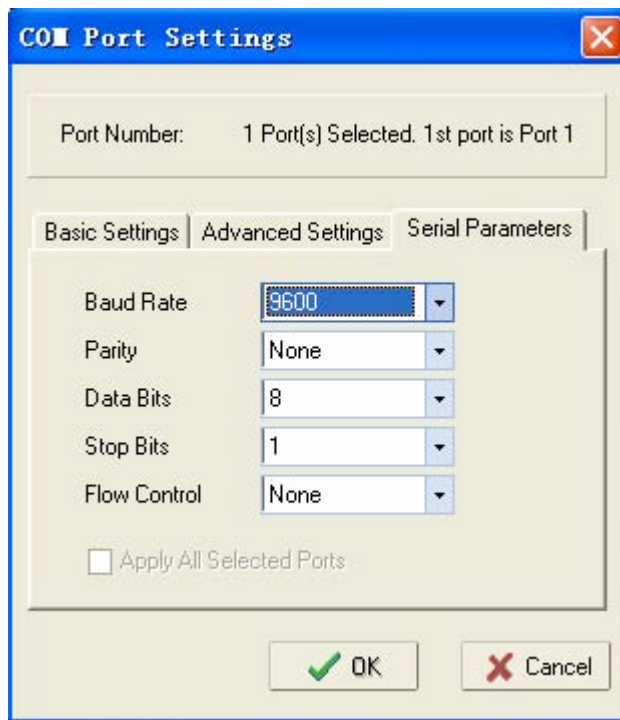

Click ok button, application configuration

- 4) Run upgrade exe.
- 5) Press “open” key, choice the upgrade procedure in the computer.
- 6) Press “open” key, the computer start to upgrade the software of instrument.
- 7) Software under upgrade, the apparatus will clue on “Configuring Mode • • •”.
- 8) After the software upgrade finish, the apparatus will clue on “Upgrade finished • • •”.
- 9) Firmware upgrade finished.
- 10) Click remove equipment, to remove the equipment mapping.
- 11) Resume configuration.

Network Enable Administrator Choice configuration function.

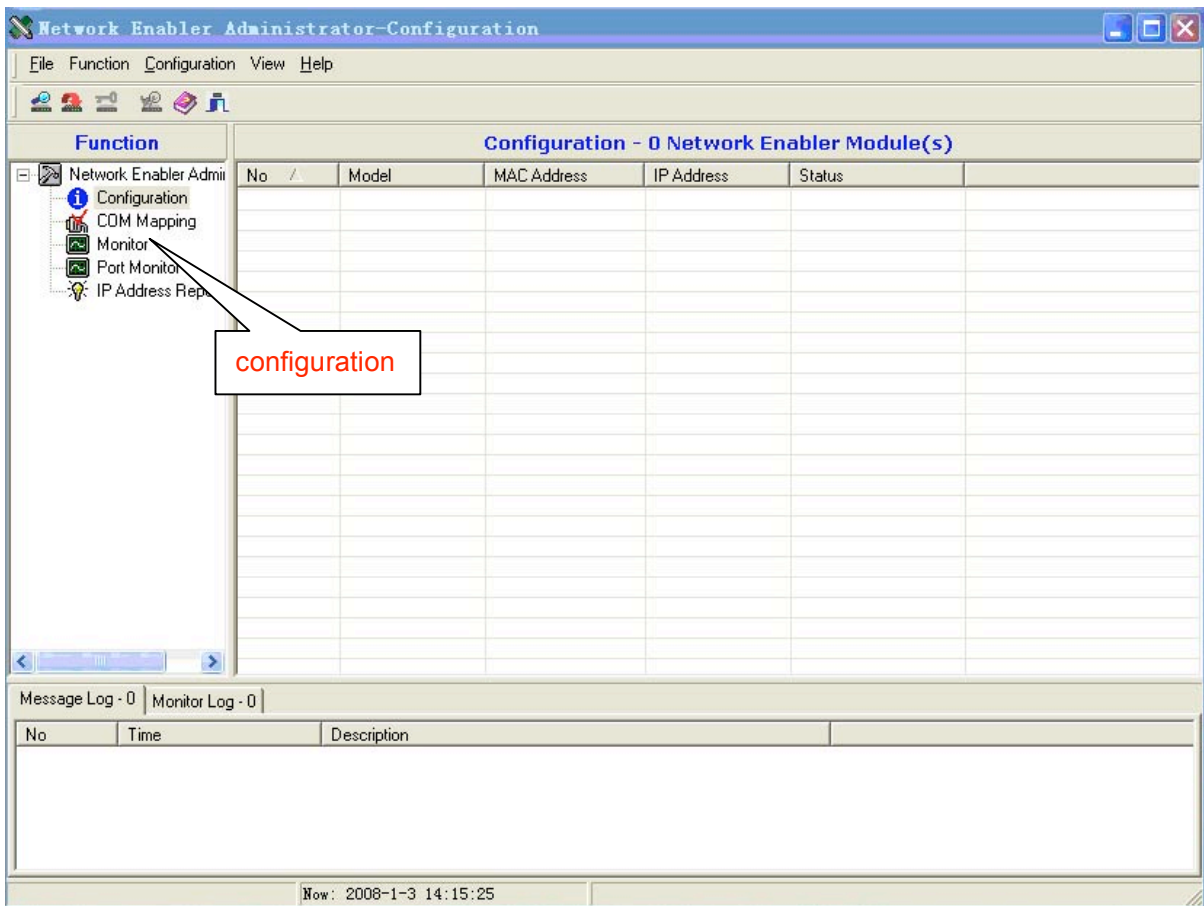

Double click the searched IP address, open the property page to choice the network option.

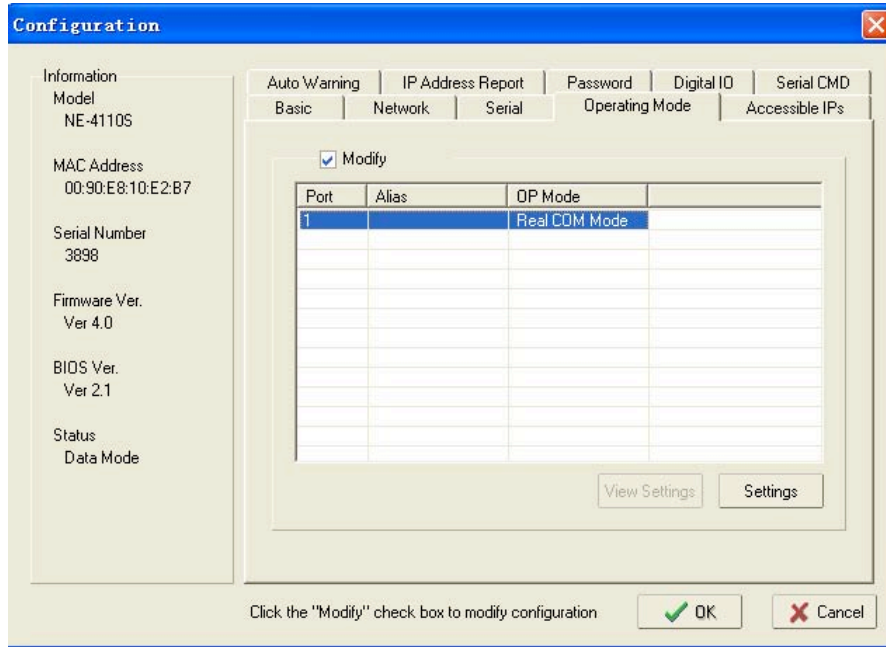

Operating mode choice "TCP Server Mode".

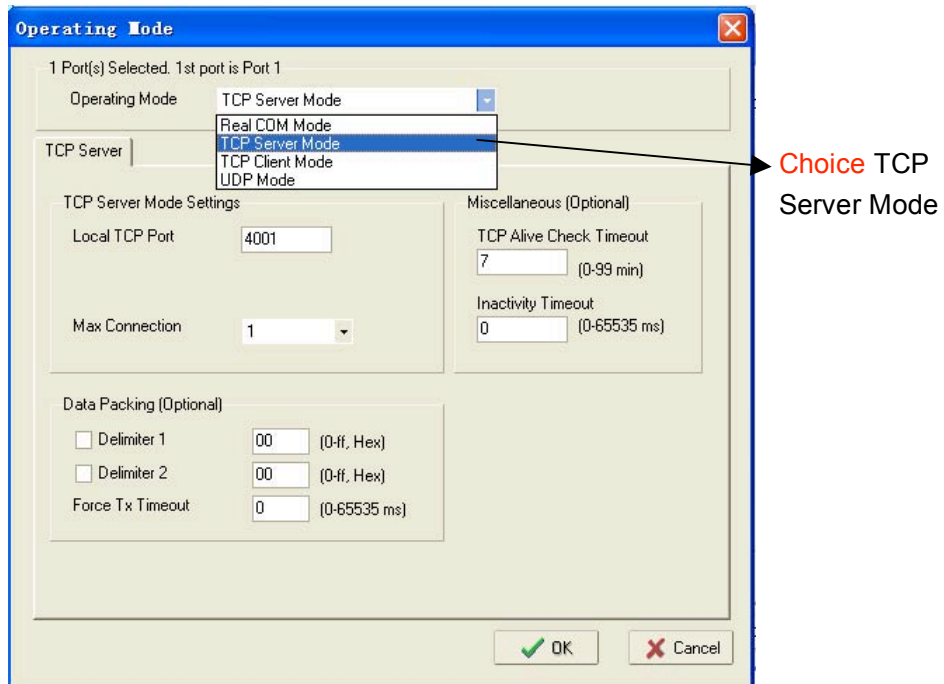

Click Ok button, close Network Enable Administrator.

- 12) Restart the apparatus after closing, enter the system parameter configuration interface to reinstall system parameter.

Note: Upgrade procedures will not be noticed in additional, users can land website www.BOECO.com and download the latest version for the procedure.

Chapter Seven Failure Analysis and Troubleshooting

In this chapter, we briefly represent possible failures, reason analysis and troubleshooting

1. Failure Analysis and Troubleshooting

No.	Phenomenon	Failure Analysis	Troubleshooting
1	No display and the two beeps missed when power on	Disconnected power supply	Check power supply for correct connection
		Bad fuse	Replace it (250V 8A $\Phi 5 \times 20 \text{mm}$)
		Switch failure	Replace it
		Others	
2	After power on, the instrument beeps twice, and then the LCD display: "Please insert Block!" , with beep warning sound.	Bad connection between the block and the main body.	Power off, pull out the block, and then re-insert the block, and power on.
3	Error Message when running: "Please check error" with any information below: "Temperature sensor disconnect" "Temperature sensor1 disconnect" "Temperature sensor2 disconnect" "Temperature sensor3 disconnect"	Bad sensor connection or sensor broken	Power off, pull out the block, and then re-insert the block, and power on.
			Contact distributor or manufacturer
4	Error Message when running: "Please check error" with the information like "Heat sink sensor disconnect"	Bad sensor connection or sensor broken	Power off, pull out the block, and then re-insert the block, and power on.
			Contact distributor or manufacturer
5	Error Message when running: "Please check error" with the information like "Hotlid sensor disconnect"	Bad sensor connection or sensor broken	Power off, pull out the block, and then re-insert the block, and power on.
			Contact distributor or manufacturer
6	Abrupt change in heating speed or bad temperature control accuracy	Ventilation jam	Clear the jam
		Bad connection	Open the device, check the connectors for reliable connection
		Cooling module failure	Contact distributor or manufacturer

7	Significant change in cooling speed, or unavailable temperature below ambient one	The ambient temperature or humidity is too high, which is beyond the normal working condition of the instrument.	Please regulate the ambient temperature and the humidity.
		Cooling module failure	Contact distributor or manufacturer
		Fan failed or stopped	
8	The block cannot be heated or cooled.	Bad temperature sensor.	Contact distributor or manufacturer
		Malfunction of all cooling modules	
9	Lid cannot be heated.	Set the hot-lid as "OFF" in the system parameter setting interface	Set the hotlid's state as a certain temperature value.
		The control temperature time is set as "--:--" in the file edit interface, which lead to the hotlid closes automatically.	Set the temperature control time in digital.
		Loose connection between connectors	Contact distributor or manufacturer
		Lid heater failure	
10	Abnormal characters displayed in the LCD	Lid sensor failure	
		Bad contact of chip with its socket	Contact distributor or manufacturer
		Chip malfunctioning	
11	Inactive keys	Film panel destroyed	Contact distributor or manufacturer
12	The setup of parameters is invalid	Failure to press "Save" button after the setup of parameters	Please refer to Section 1.2, 2.2 and 3.2 of Chapter 4.

13	Reagent in the reaction tubes evaporated	Failure to set hot-lid temperature, but set the hot-lid as "OFF"	Please refer to 《How to set the parameters》 in the Section 1.2, 2.2, 3.2 of Chapter 4, to set the temperature of hot-lid.
		The reaction tubes are placed unevenly	Adjust the hole location of reaction tubes, and place the tubes symmetrically.
		The lid of reaction tubes are closed untightly	Please close the lid of tubes tightly before put them into the instrument.

Note: During warranty terms, please contact distributor or manufacturer if there is a need to open the device to check a failure listed in the above table. Each instrument with the same or different brand has their own control temperature features, including cooling & heating rate, stability and fluctuation; meanwhile, the biological experiment has its own features such as indeterminacy, and easy to be affected by the surroundings, therefore, any PCR program that is achieved on one instrument successfully, maybe cannot be achieved the same successful result. Once you change instruments to do the same experiment, you'd better adjust the PCR running program, so as to get an ideal state.

2. Spare Parts list

NO.	Symbol	Name
1	BYQ505801100000	Driving board
2	BYQ505801200000	CPU board
3	BYQ505801410000	Transform parts
4	BYQ605802000000	Block parts
5	BYQ154314200010	Fuse
6	BYQ165200000020	Resistance
7	BYQ902102100070	Peltier
8	BYQ152303000250	Power Plug
9	BYQ155420000070	LED display
10	BYQ905801300010	Touch panel
11	BYQ158206000040	Power supply
12	BYQ905801300020	Touch panel shell

Appendix 1 Wiring Diagram

(This diagram is regarded only as a reference, and it is a subject to change without prior notice. We apologize for any inconvenience caused.)

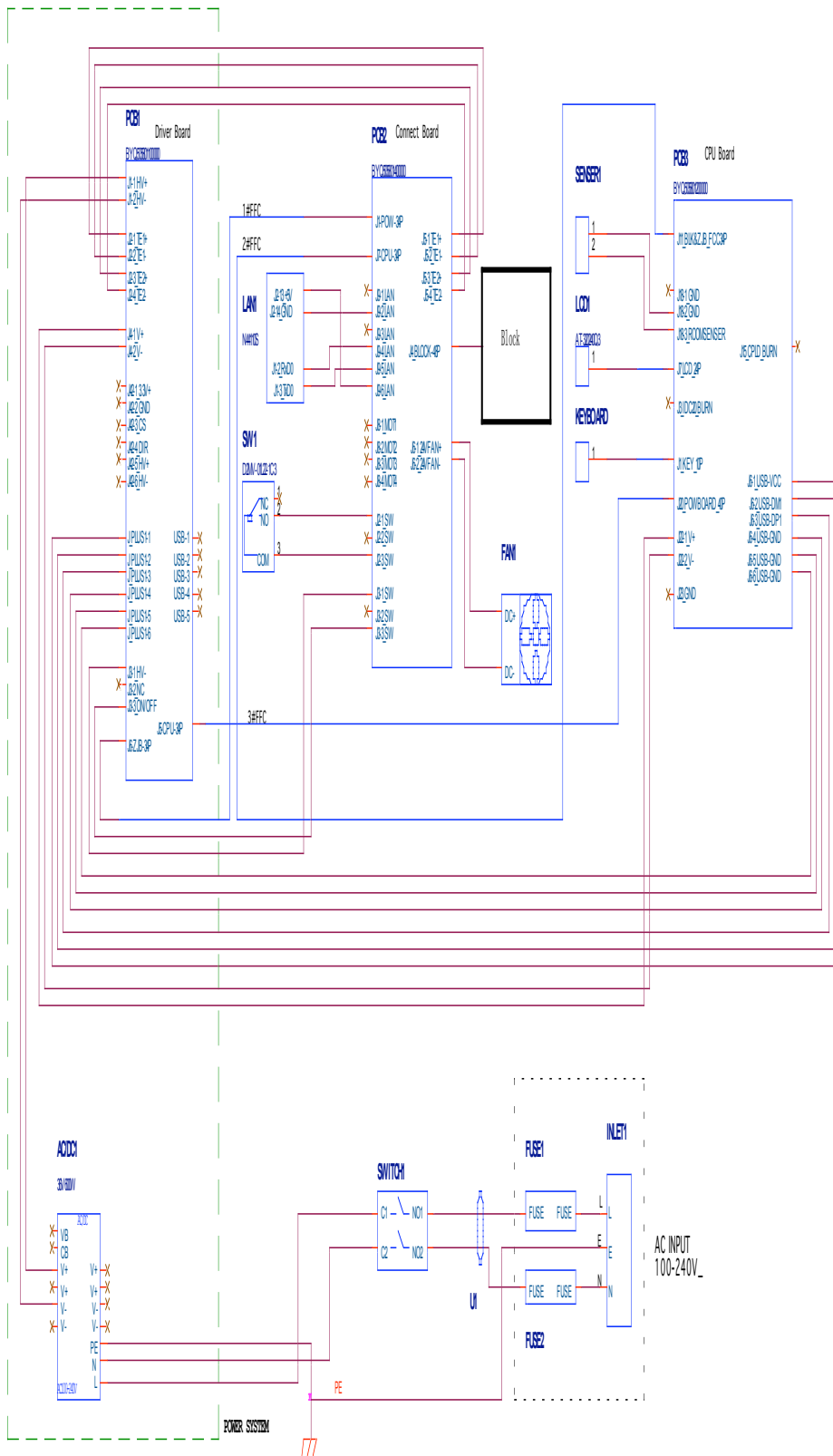

Appendix 2 Parameter Value & Meaning

Item	Parameter	Meaning	Range	Note
1	Temp(C)	Temp. Control point	4.0~99.0	
2	Time	Time of Temp. Control (mm:ss)	--:-- (set the value before ": "through "Function" key.)	The time of Temp. control is long limitlessly, meanwhile, the hotlid closed.
			00: 00~59: 59	
3	Ramp(C/S)	Ramping Rate (°C/Second)	0.1 ~2.0	
			#.#	Maximum of Ramping Rate
4	+Temp	Temp. Gain of Every Cycler	0.0~9.9	
5	+Time	Time Gain of Every Cycler (mm:ss)	0:00~9:59	
6	Cycle ¹	Section Numbers	1~5	Cycle ¹ : ×00 From 00 to 00
	×00	Cycler Numbers from beginning to the end	1~99	
	From 00	The start segment of the section	X (and existed segment no.)	
	to 00	The end segment of the section.	≤X+15	
7	Grad.	Gradient Temp. Difference (°C)	0 ~30	
8	Date	Date(YY-MM-DD)	00(~99)-01(~12)-01(~31)	year-month-date
9	Time	Time(HH:MM:SS)	00:00:00~23:59:59	hour: minute: second
10	Default File	The default file name	Max. length is 11 bytes.	
11	Default User	The default user name	Max. length is 11 characters.	
12	Control Mode	Control Mode	Block	Under this mode (once reaching target temperature namely entering into the thermostatical state), the time for reagent's temperature under target temperature is less than setting time (see Fig. 1).
			Tube	Under this mode (once entering into the thermostatical state after reaching target temperature and decreasing about 3 °C), reagent's temperature can be close to target temperature very fast (see Fig. 2).
13	Sample Volume	Sample Volume (ul)	10~200	
14	Holid	State of Hot Lid: Off	Off	
		State of Hotlid: Open (□)	30~110	
15	Key Sound	Key Sound (Yes or No)	Yes/No	Humming
16	Run End Sound	Run End Sound (Yes or No)	Yes/No	Humming continuously

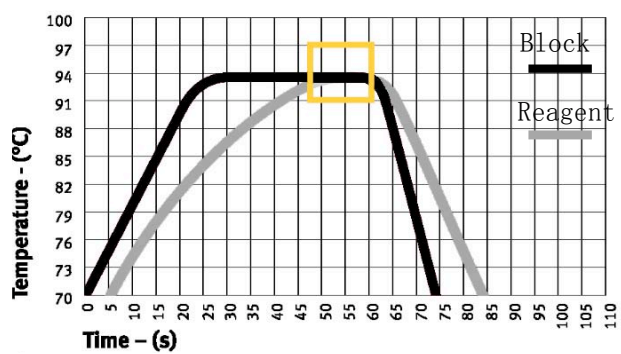

Fig. 1

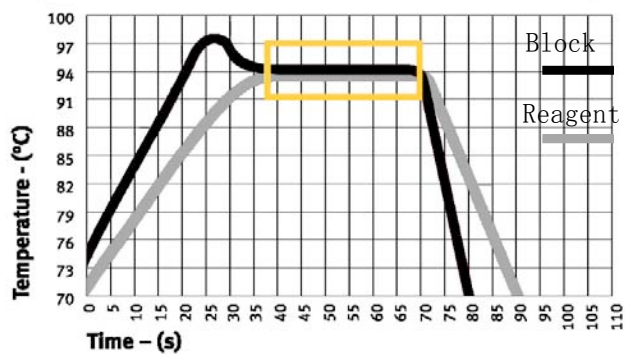
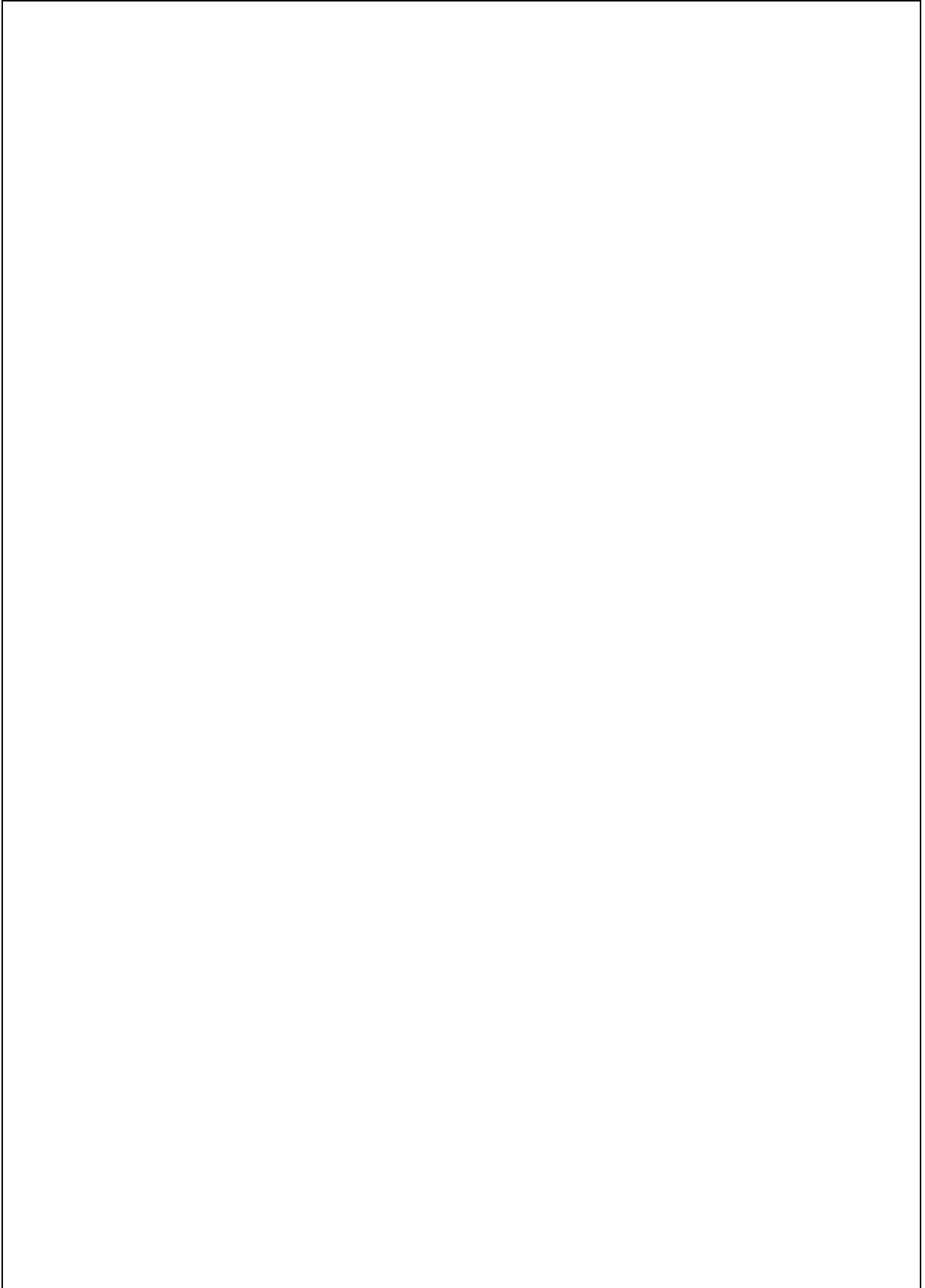

Fig. 2

NOTE:

A large, empty rectangular box with a thin black border, intended for writing notes. It occupies the majority of the page below the 'NOTE:' label.



Boeckel + Co. (GmbH + Co.) KG

P.O.Box 11 22 26

Roedingsmarkt 33, 20459 Hamburg

20422 Hamburg, Germany

Tel. +49-40-32 56 27-27

Fax. +49-40-32 56 27-41

Website: www.boeco.com